

BUILD YOUR OWN

# Fuzz Face



# The Fuzz Face

By Mitchell Hudson of [super-freq.com](http://super-freq.com), in conjunction with Joe Gore of [tonefiend.com](http://tonefiend.com).

Build your own vintage Fuzz Face!

Create a vintage-style germanium-transistor fuzz box with minimal effort and parts. This effect produces the classics sounds used by Jimi Hendrix, David Gilmour, George Harrison, Eric Johnson, and many others.



## History of the Fuzz Face

The circuit was originally produced by the Arbiter Company in 1966 and was very similar to the Sola Sound/Vox Tone Bender MK I. Originally the Fuzz Face was built using PNP germanium transistors. Later models used silicon transistors. Transistors of the type used in the Fuzz Face come in two varieties: PNP and NPN. This project will use PNP Germanium transistors. The Fuzz Face has been made and remade in many variations by different manufacturers over the years. The circuit is ripe for modifications!

**Sound:** The fuzz face sounds fuzzy and distorted. What that really means is up to your interpretation.

The input signal has a huge effect on the sound coming from the output. One of the great features of the fuzz face is that the distorted sound coming from the output can be controlled via the volume knob on your guitar. The distortion is mainly produced through signal clipping. Higher gain transistors produce more clipping and begin clipping at lower input levels. Different transistors can produce different levels gain, so choice of transistors can effect the sound.

Silicon and Germanium transistors do have different sound in the circuit. Silicon transistors generally produce higher gain than germanium transistors. Germanium transistors tend to absorb high frequencies. The result, generally speaking, is a germanium based fuzz face will have less high frequency content and less harsh clipping. Where silicon fuzz faces have harsher clipping and greater high frequency content.

# Bill of materials

You can build a Fuzz Face with a few simple tools and eleven parts. All parts are fairly standard and easy to find.



# What you need

## Tools:

- Soldering Iron
- Solder
- Wire Cutters
- Wire strippers
- Needle nose pliers

## Parts:

- 1x 100K resistor
- 1x 33K resistor
- 1x 470 ohm resistor

- 1x 8.2K resistor
- 1x 2.2 $\mu$ f capacitor
- 1x 0.01 $\mu$ f capacitor
- 1x 20 $\mu$ f capacitor
- 2x PNP Transistors

\* Read the notes for substitute values for these parts.

**Resistors:** Any type from 1/8 watt to 1/2 watt work fine. The standard 1/4 watt types are the easiest to find.

- R1 100K
- R2 33K
- R3 470
- R4 8.2K
- R5 4.7K (only needed if adding a power-indicator LED)

The resistors listed above are the values used in the original Fuzz Face. These values are not critical, and can be fudged to some degree. Due to the variation in transistors, especially Ge

types, other values might even sound better! Feel free to experiment.

If you can't find an 8.2K resistor, a 10K will work just fine. If 470 ohm is not available, 1K also works.

**Capacitors:** Any type will work. The larger values are electrolytic types, these are usually polarized and have a positive and negative lead. (The positive lead is usually longer, and the casing usually indicated the negative lead side with a contrasting color.) These must be oriented correctly.

- C1 2.2 $\mu$ f
- C2 0.01 $\mu$ f
- C3 22 $\mu$ f

Capacitor values are also open to interpretation, even more so than resistor values. Feel free to experiment with these. The 2.2 $\mu$ f can be anything from 0.001 to 10 $\mu$ f. I like the values from 0.1 to 4.7 $\mu$ f. This cap determines how much bass goes into the effect. Larger values allow more bass at the input.

The 22 $\mu$ f value should be kept large, anything from 10 $\mu$ f to 100 $\mu$ f is fair game. This cap determines gain up to a certain frequency. Larger caps allow increased gain on a wider frequency band, while smaller values increase gain only on high frequencies.

The 0.01 $\mu$ f cap on the output can be almost anything. This cap determines how much bass is passed at the output. Larger values allow more bass.

**Potentiometers:** Potentiometers (pots) come in different tapers. The taper describes the change in resistance over the range of rotation. Most common types are linear (B), and Audio taper (A).

- Gain B1K
- Volume A500K

For convenience the project will show pots mounted to the circuit board. This saves time wiring and conveniently mounts

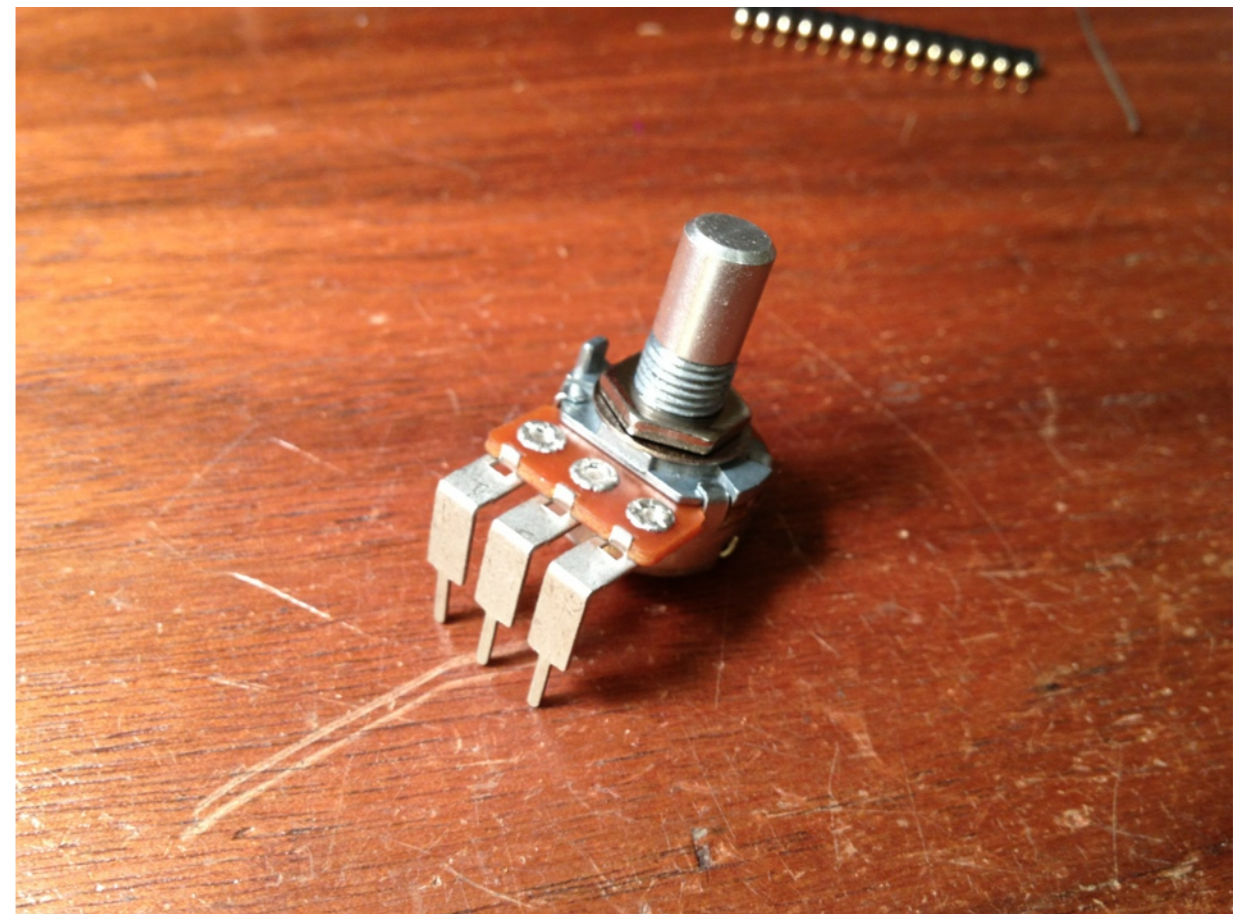

the circuit board to pots inside the case. If you can't find the same type of pots you can easily run wires to the board from the pots.

**Transistors:** This can be any PNP type. The images shown in



the description use AC128 germanium types. For a silicon Fuzz Face sound, 2n3904 transistors work well and are easy to find.

- 2x PNP transistors

**Jacks:** You'll need a mono and stereo input jack. (The effect is mono, but a stereo input jack acts as a "kill switch" when no plug is inserted, conserving battery life.)

- 1x Stereo 1/4" input
- 1x Mono 1/4" output

**9V battery snap:** We need something to connect the battery. This project doesn't have DC adapter. NOTE: The project runs

from a -9v supply and the battery is wired in reverse. Using a DC adapter would send all of the noise from everything else on the supply into the power for this effect.

Not having a DC adapter is not a huge drawback since the project uses very little current, especially if you opt to build it without a power-indicator LED. A single 9V battery can last for months and months, so long as you make sure to disconnect your cable from the input jack when not using the pedal.

**Stripboard/vero board:** This project uses vero board, also known as strip board. Basic perfboard features a series of holes coated in conductive material, but none of these holes are pre-connected. Vero board, on the other hand, is laid out in pre-connected rows, so that any wires soldered into the same row are instantly connected. I like the phenolic resin type, but fiberglass works just as well.

**Solder:** Any solder type suitable for electronics.

**Box:** You can build this into just about anything. The classic "MXR-type" boxes are easy to find. They are a good size and easy to work with. There are several brands, all based on the Hammond 1590B.

# Building the Fuzz Face

Building an awesome fuzz box is easy with a few tools and an hour or two of spare time.





# Build the Fuzz Face

## Board Layout

The first step is to cut a piece of vero board to size for the project. You'll need a piece eight x seventeen holes, with seventeen copper strips running eight holes in length. **NOTE: Not all vero board has lettering and numbering.**

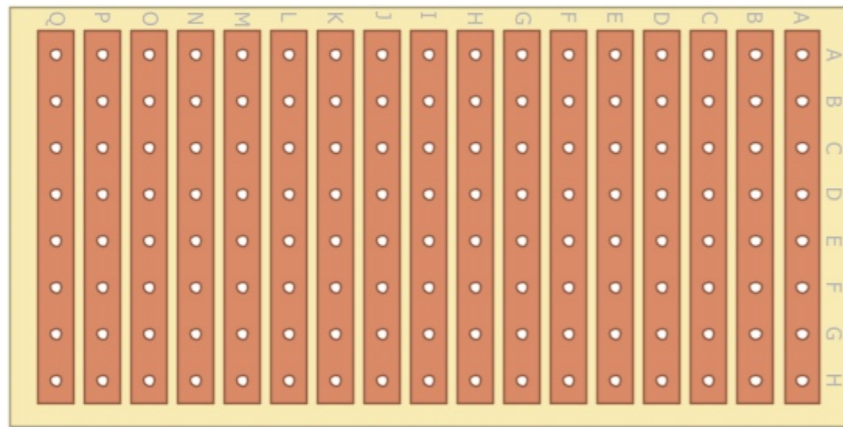

I like to cut the board across the holes, rather than trying to cut between the strips of copper.

I marked the line to cut with a pen, leaving eight holes, the I cut with a cheap hardware-store saw. I filed along the edges to smooth them. You might also buff the copper side with a little steel wool.

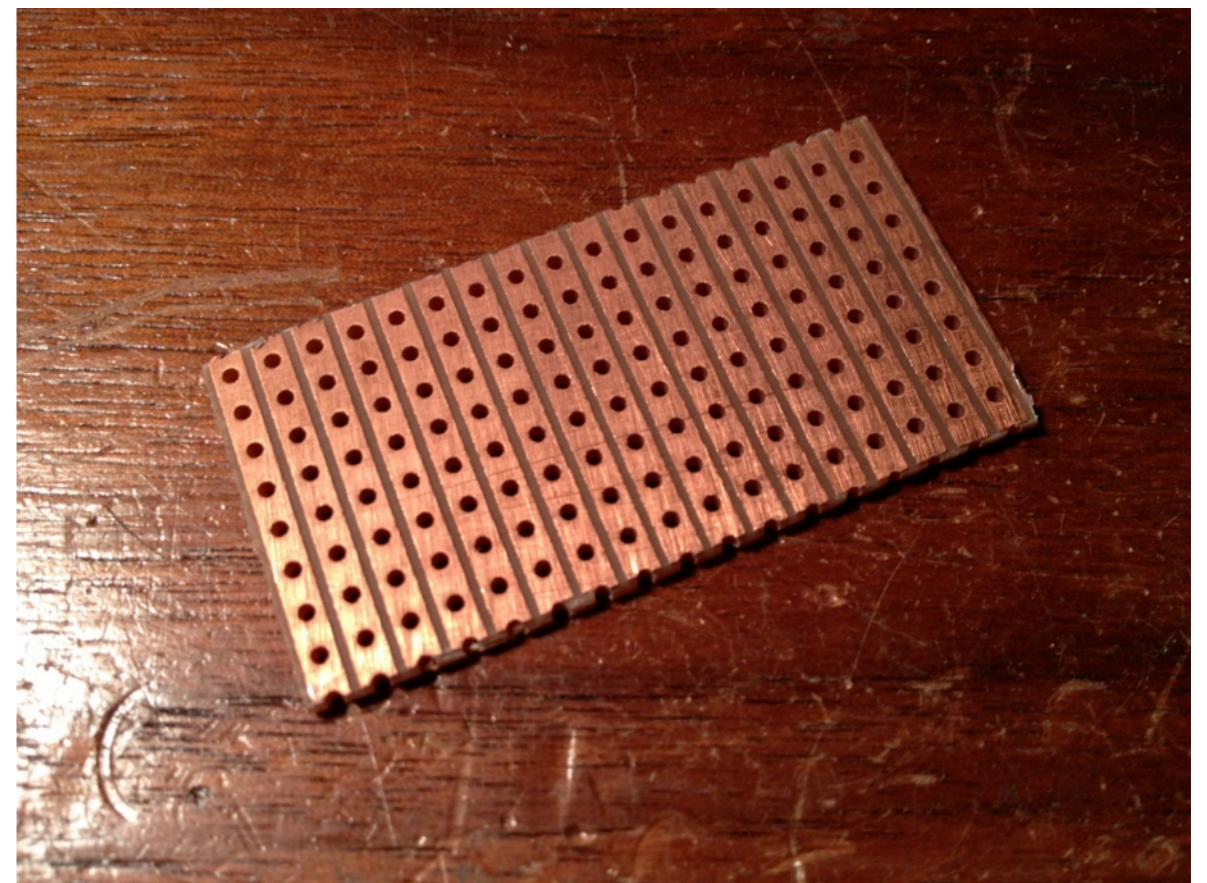
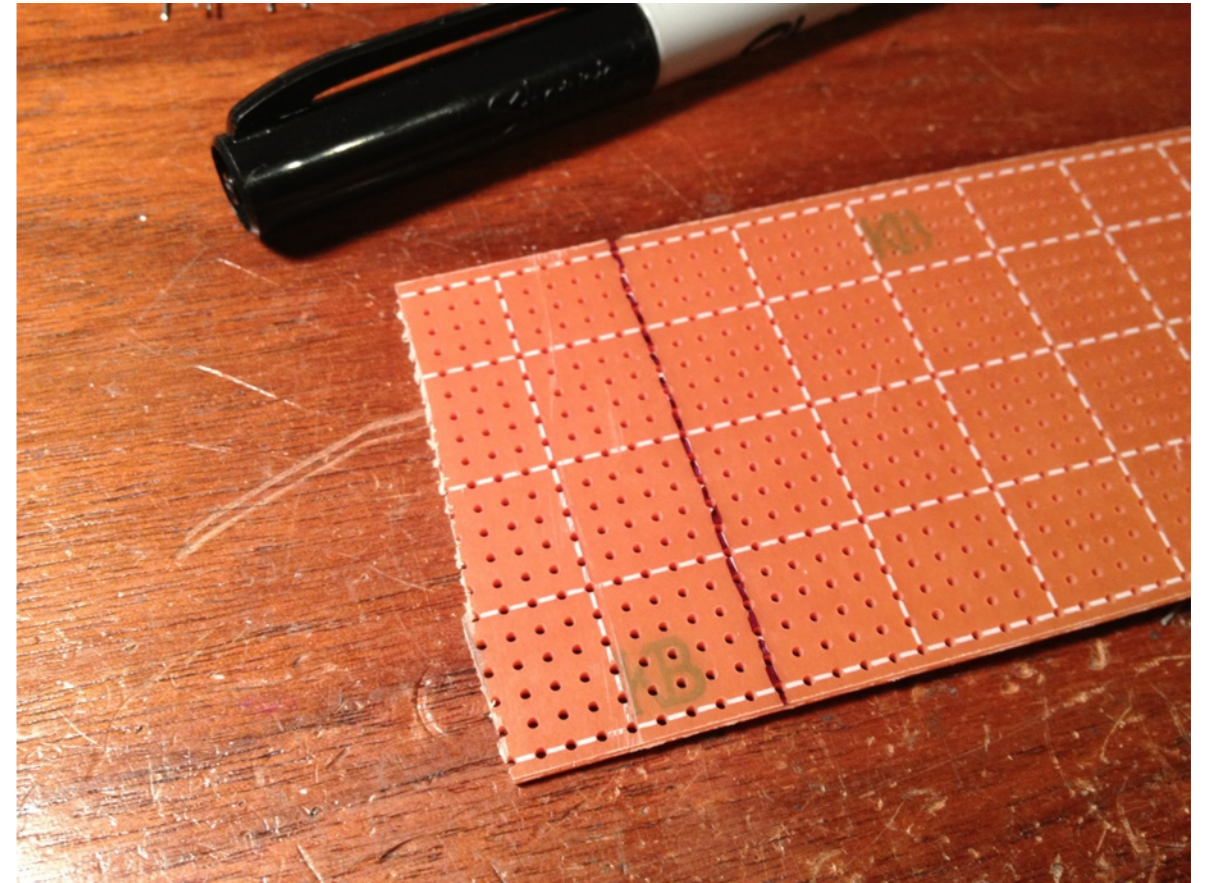

Cut a 1 1/2" length of wire and solder it between A and L on column C. Clip the ends of the wire close to solder joint.

It might look something like the picture below when finished.

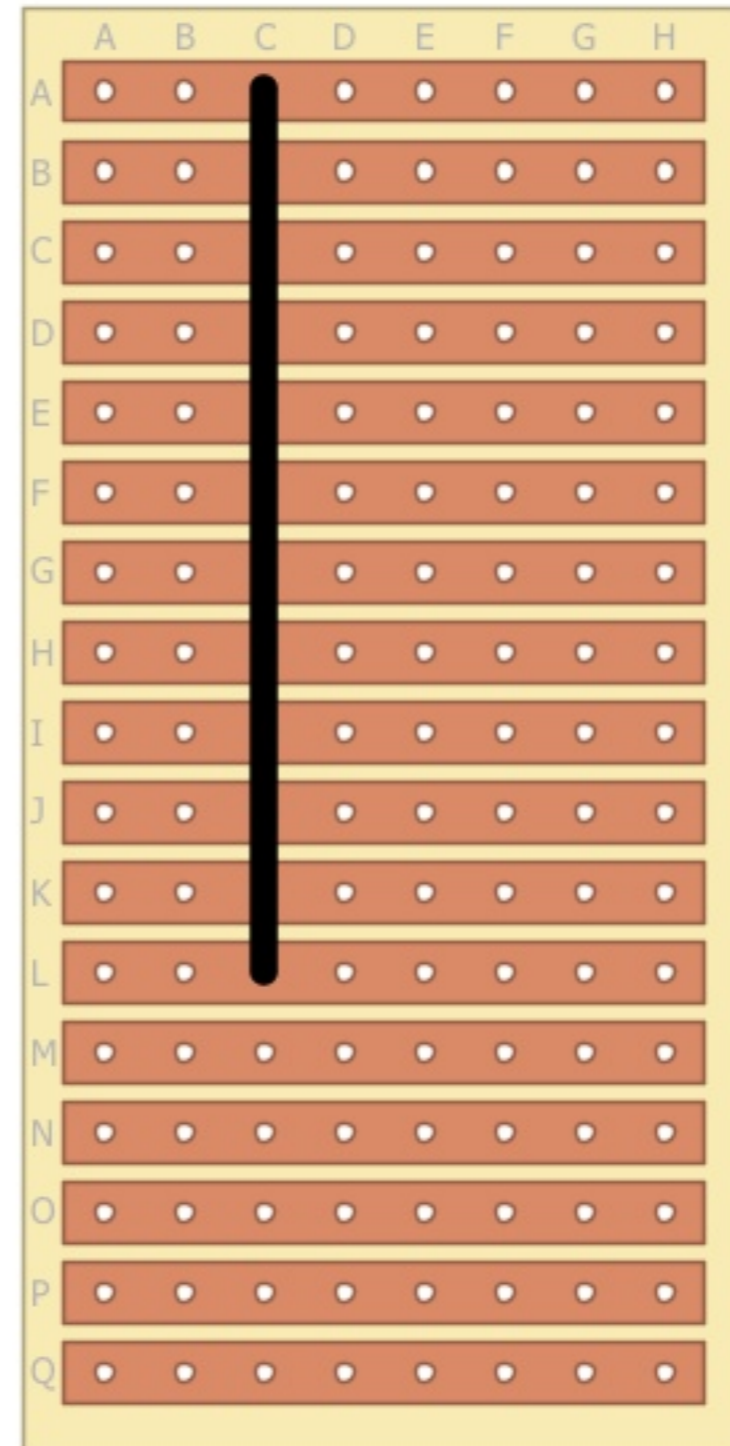
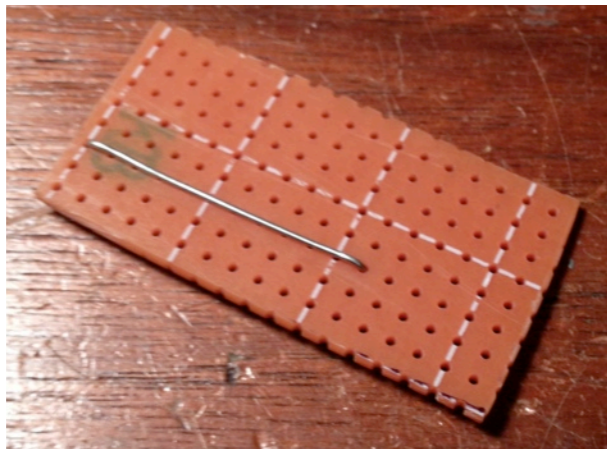

Cut a 1/2" length of wire and solder it between L and M on column D.

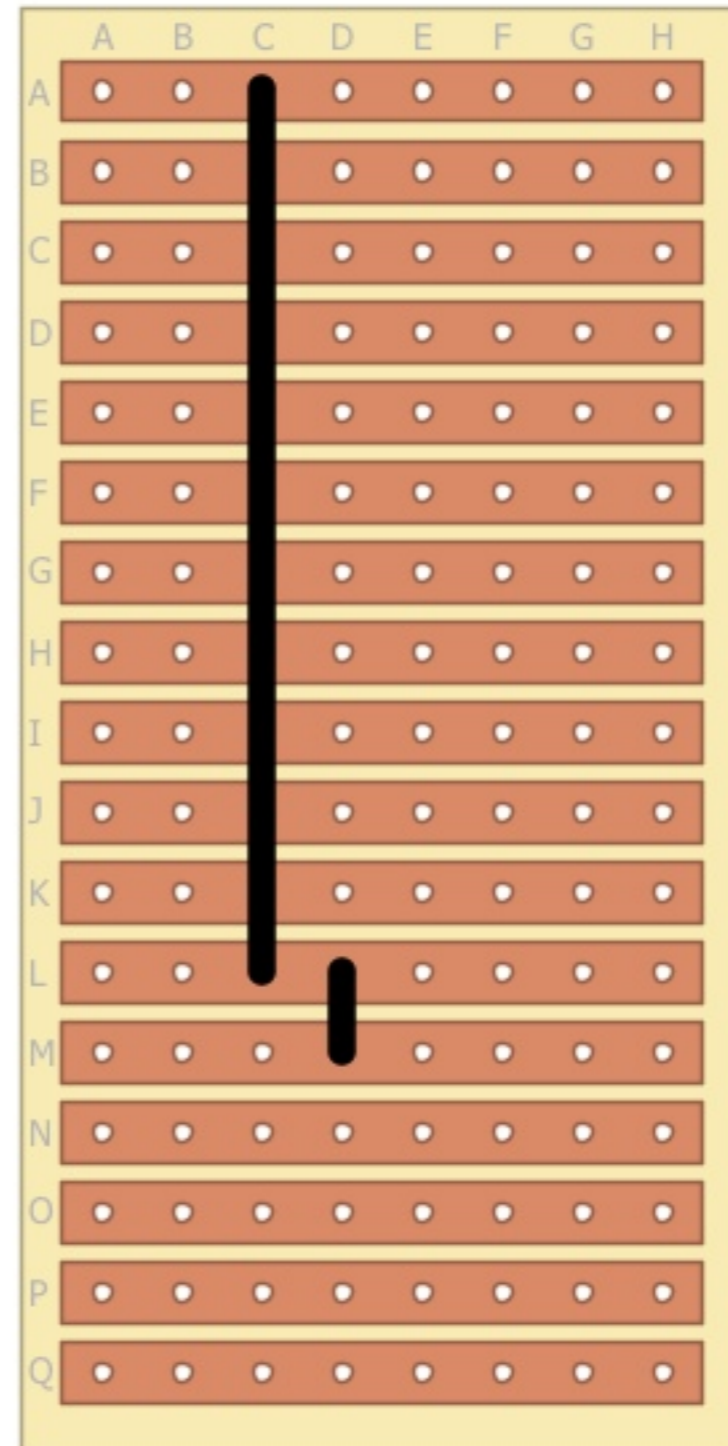

Cut an  $7/8$ " length of wire and solder it between F and J on column E.

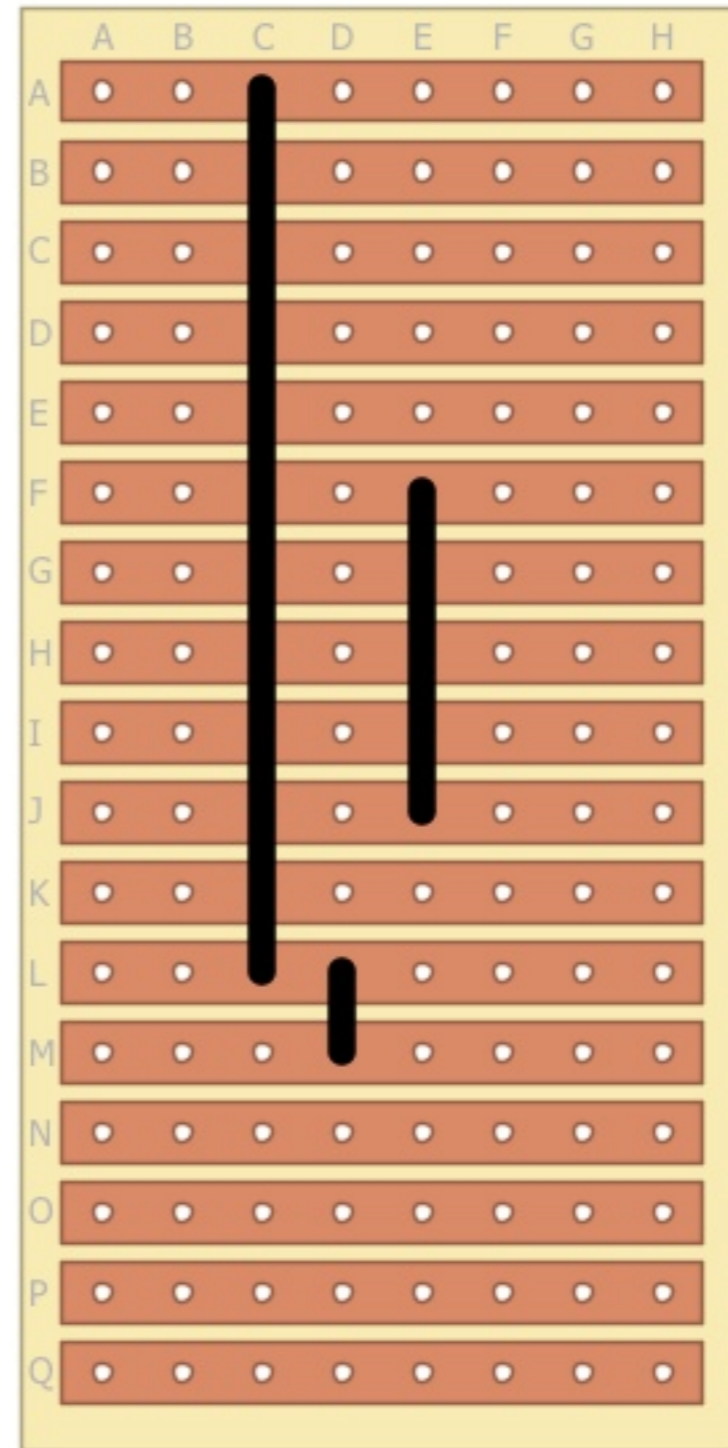
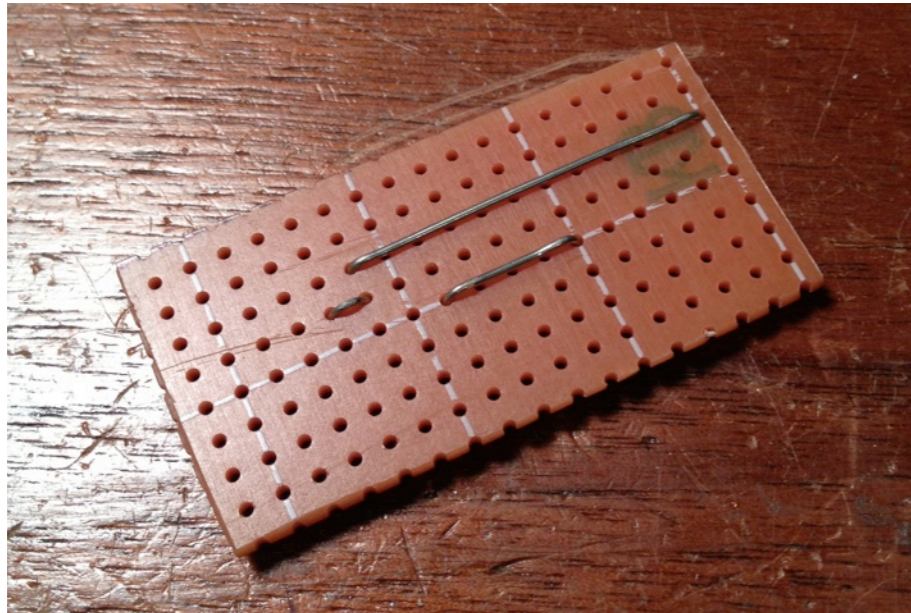

Solder an 8K2 resistor between row G and N in column A.

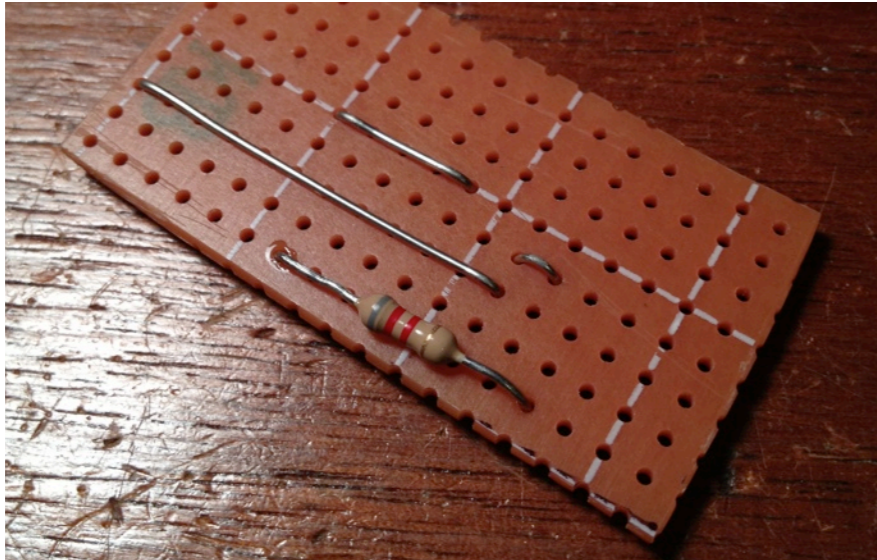

(I'll use this Fuzz Face schematic to illustrate the progress of our build, highlighting each component in red as we add it. Note that while this particular specifies 2N1305 transistors, I'm using AC-128s. Most PNP-style germanium transistor work fine, as do many silicon-type PNP-transistors.)

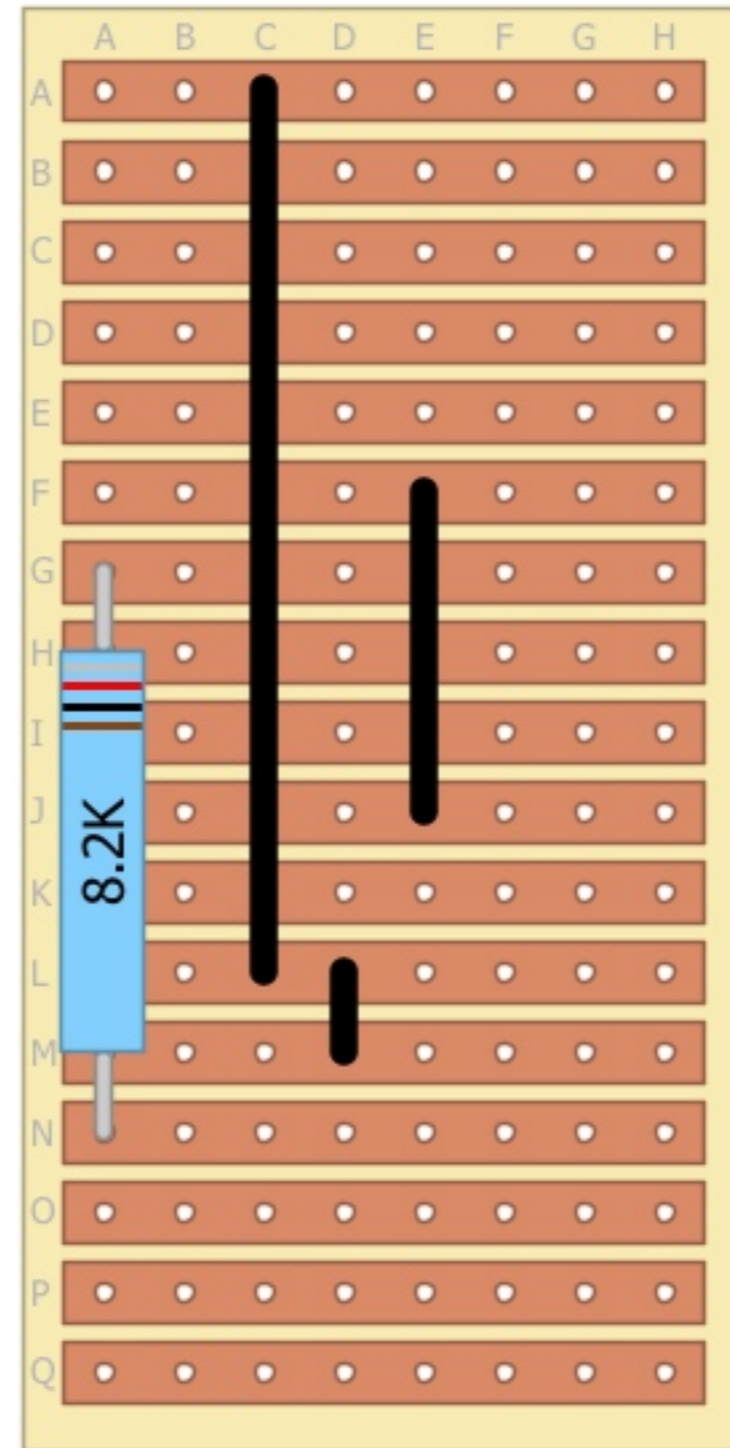
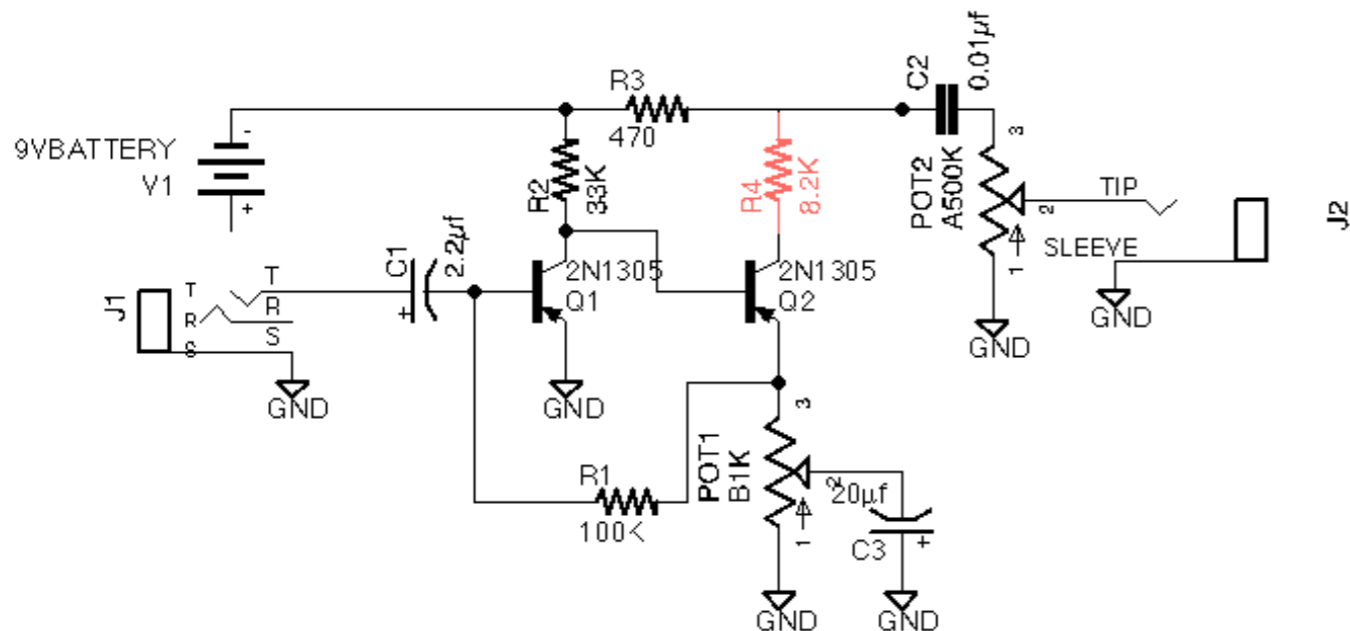

Solder a 100K resistor between row E and K in column D.

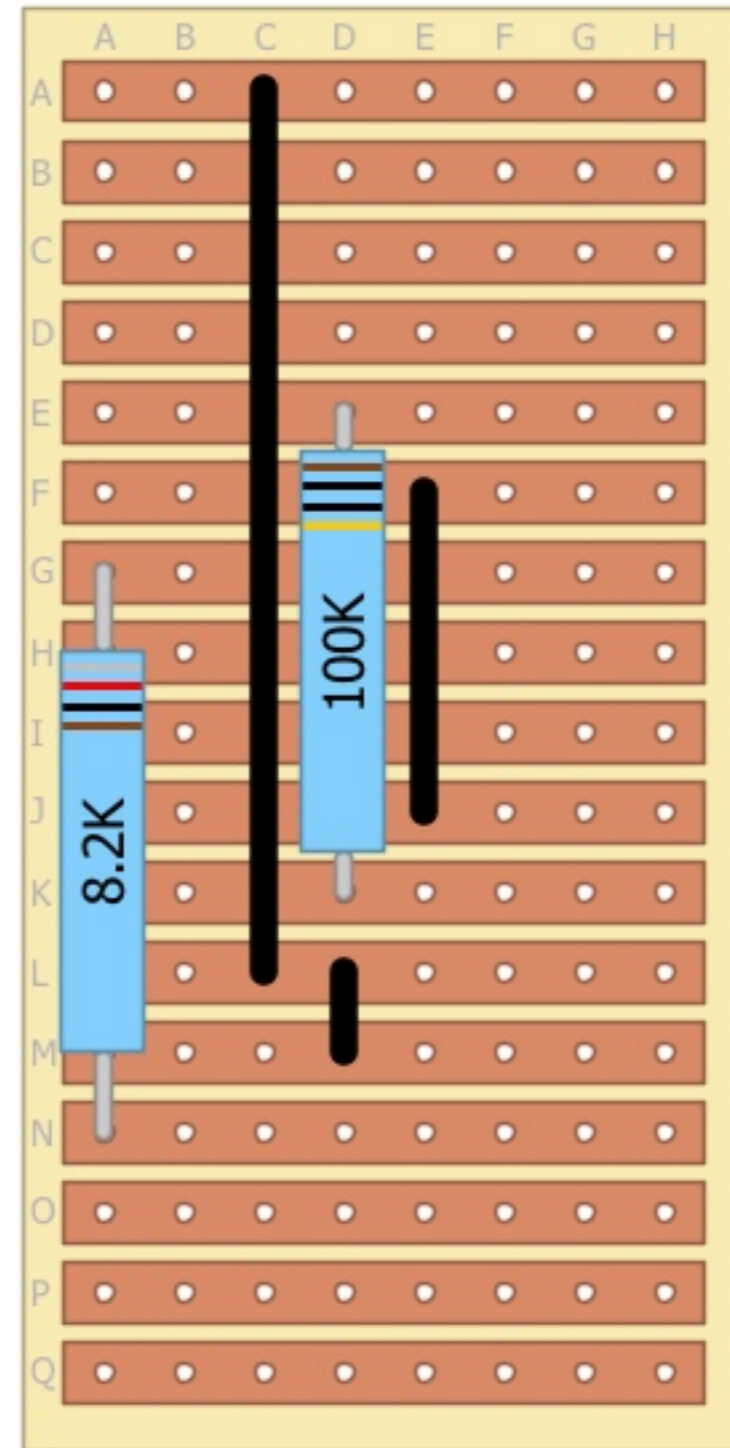
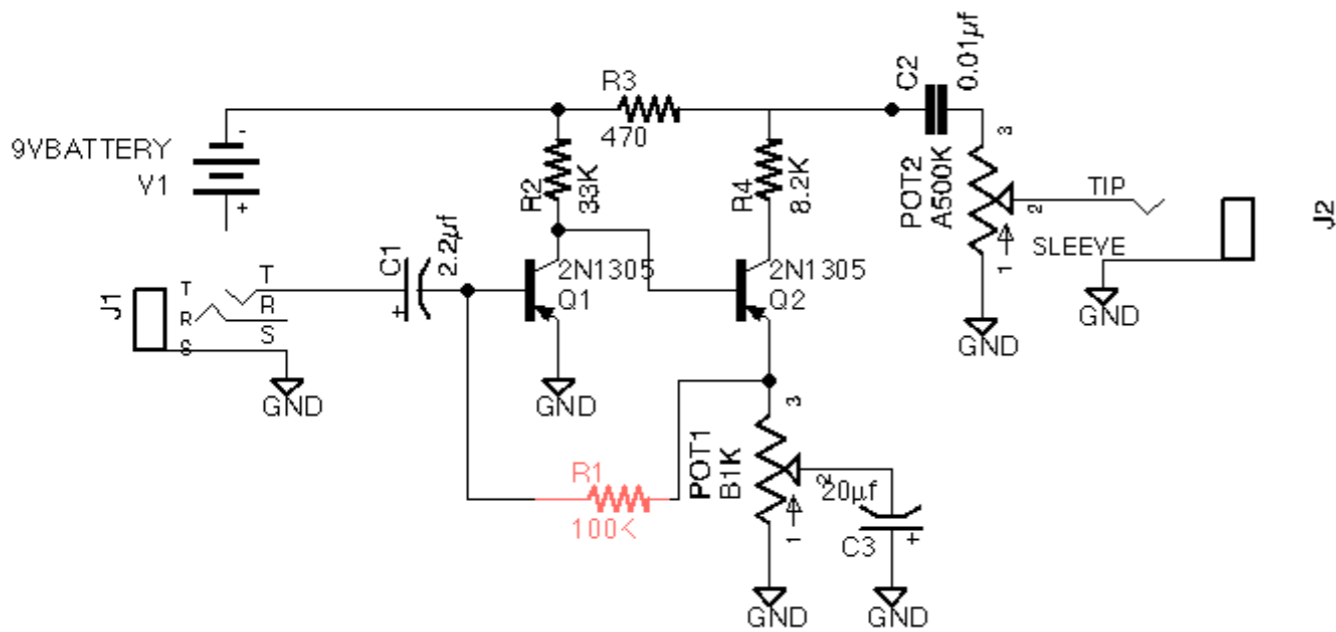

Solder a 470 ohm resistor between row I and N in column G.

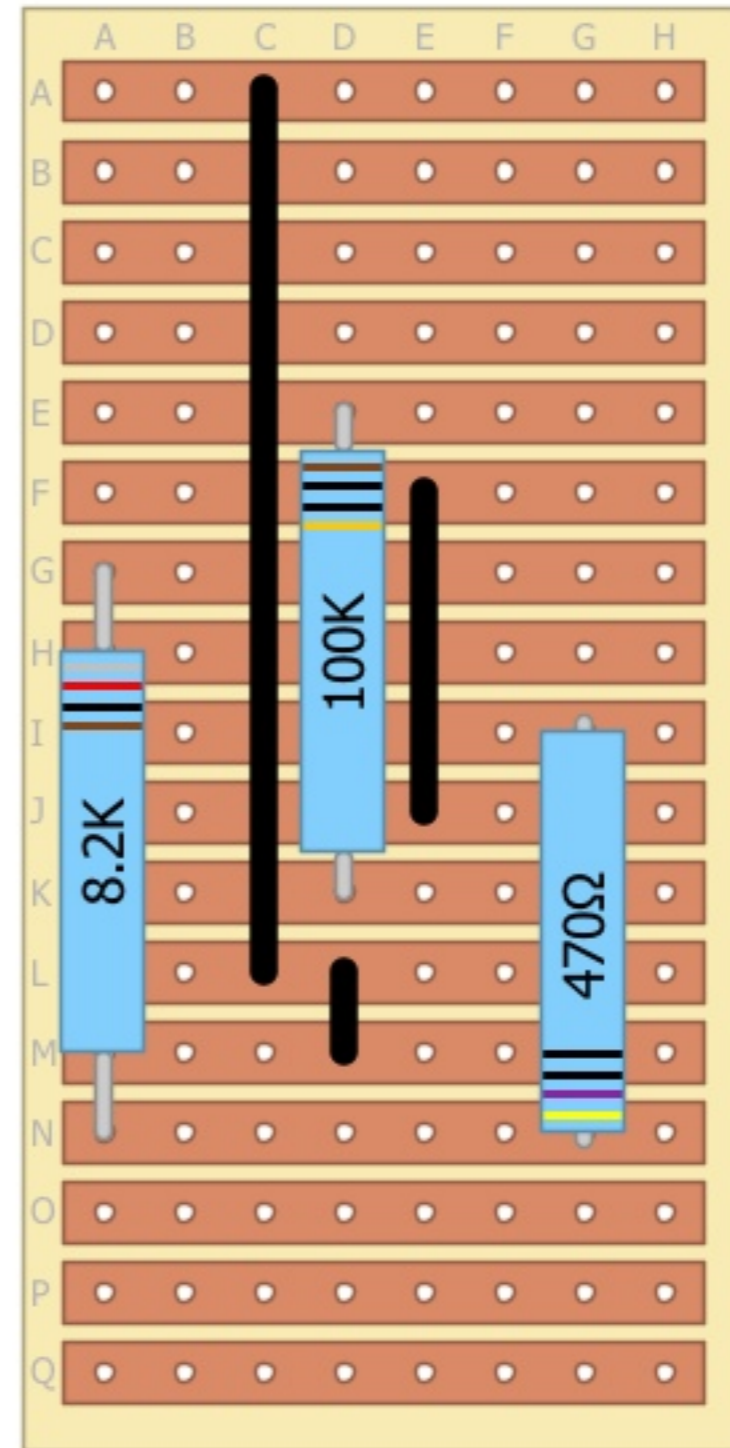
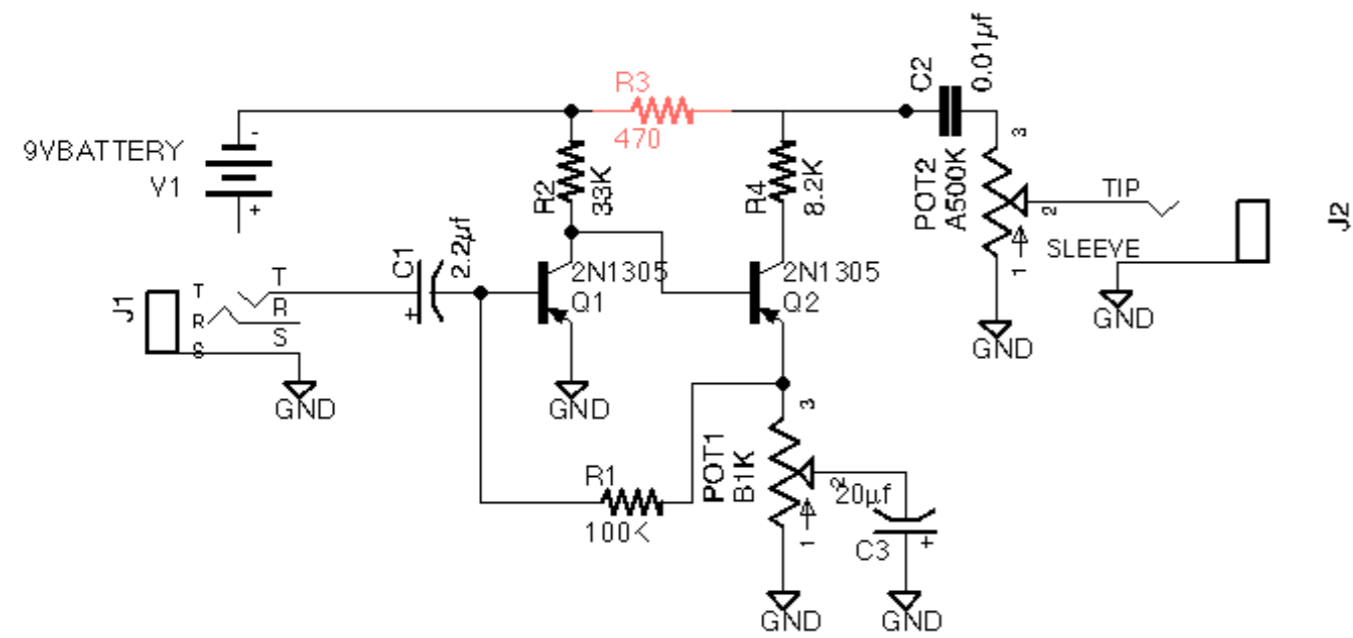

Solder a 33K resistor between rows I and J in column B.

This resistor stands on end, since it must connect two adjacent holes.

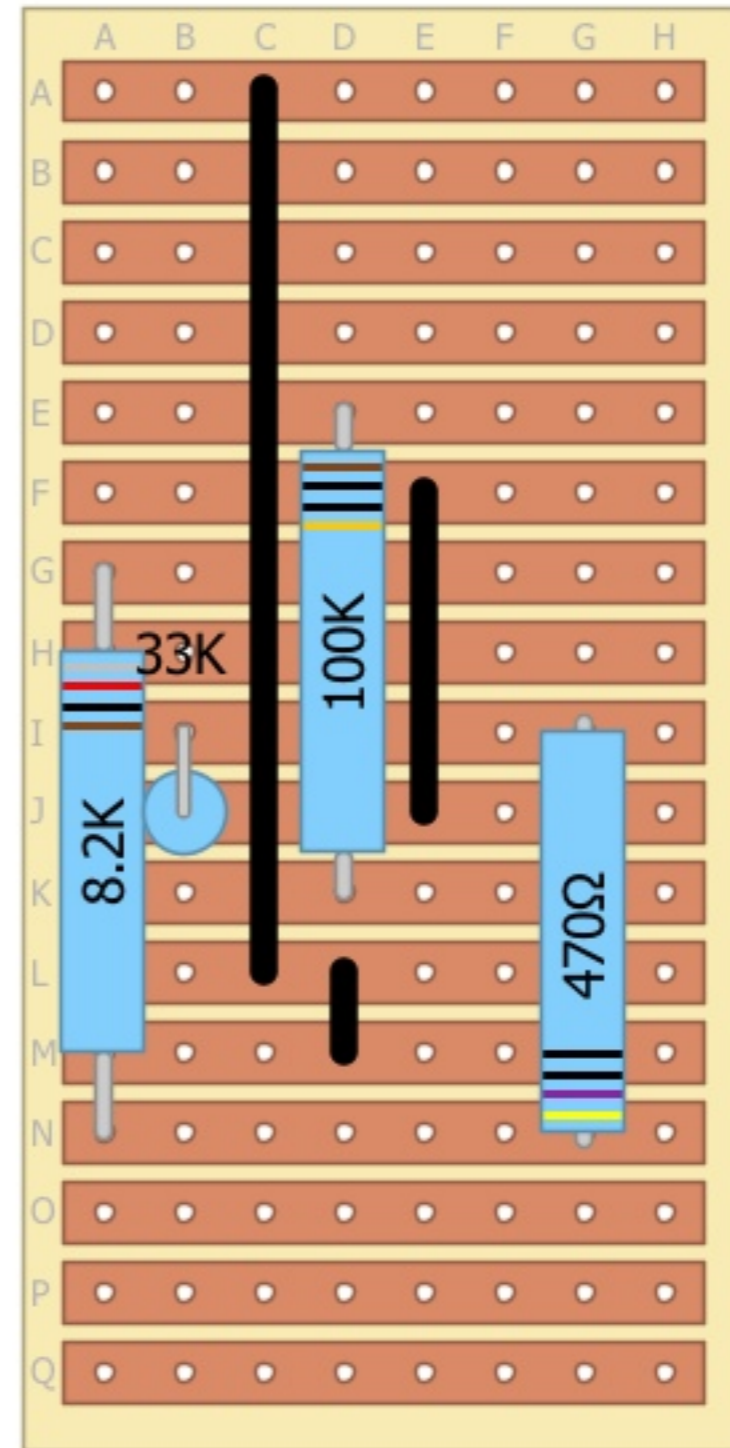
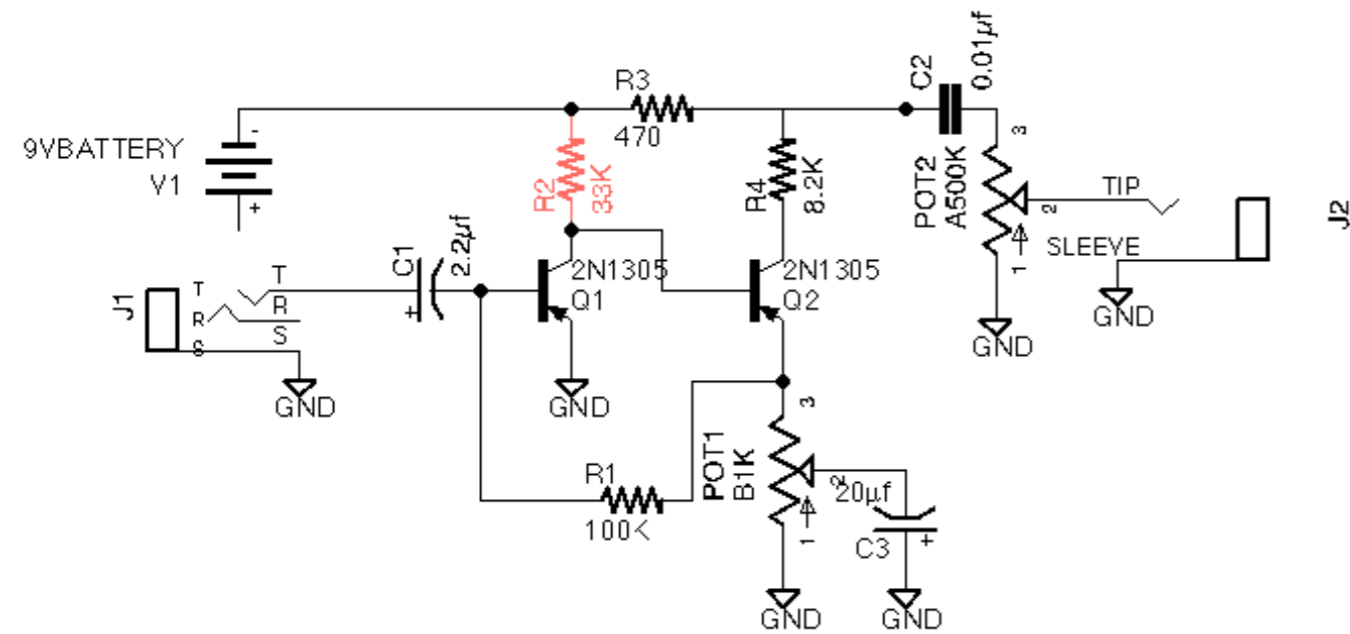
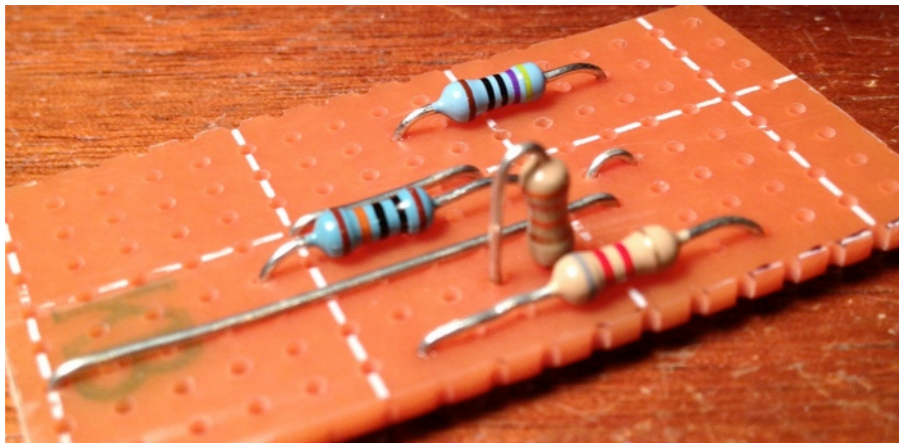



Solder a 0.01 $\mu$ f capacitor between rows N and Q in column F.  
 (Capacitors of this value come in several different types, and their appearance may vary.)

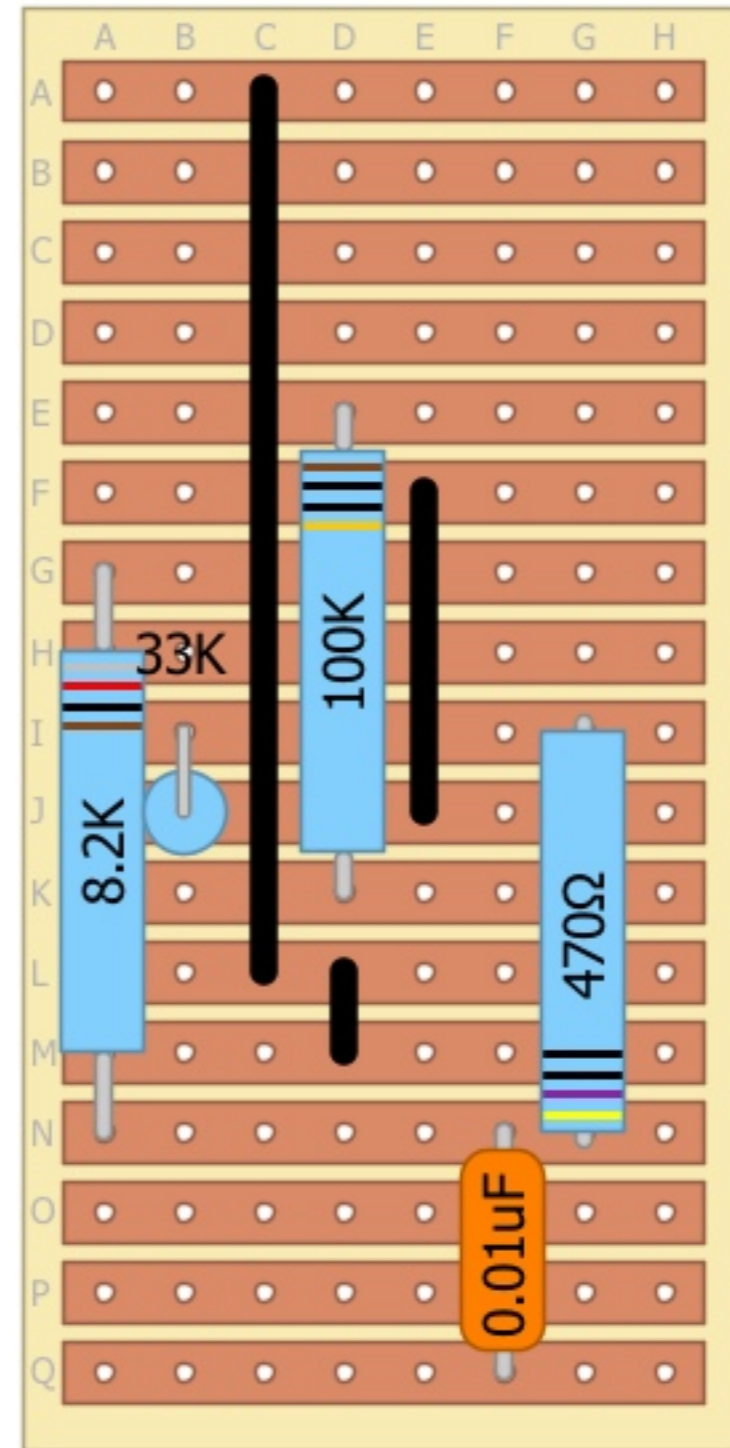
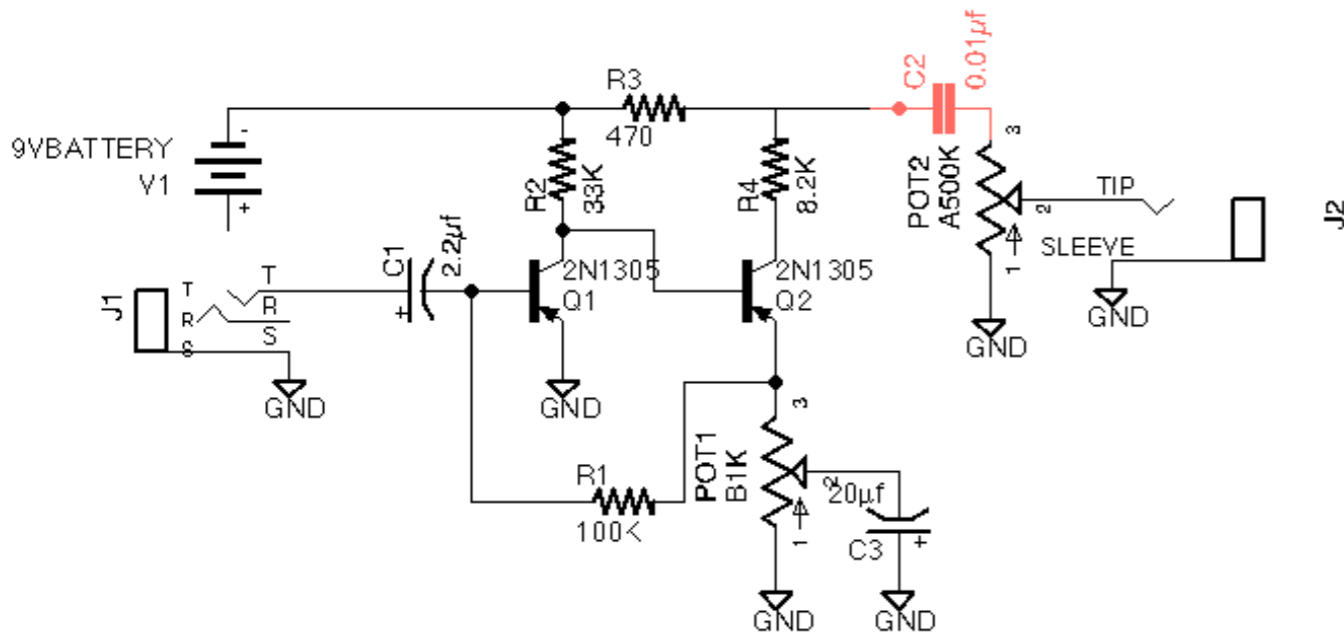
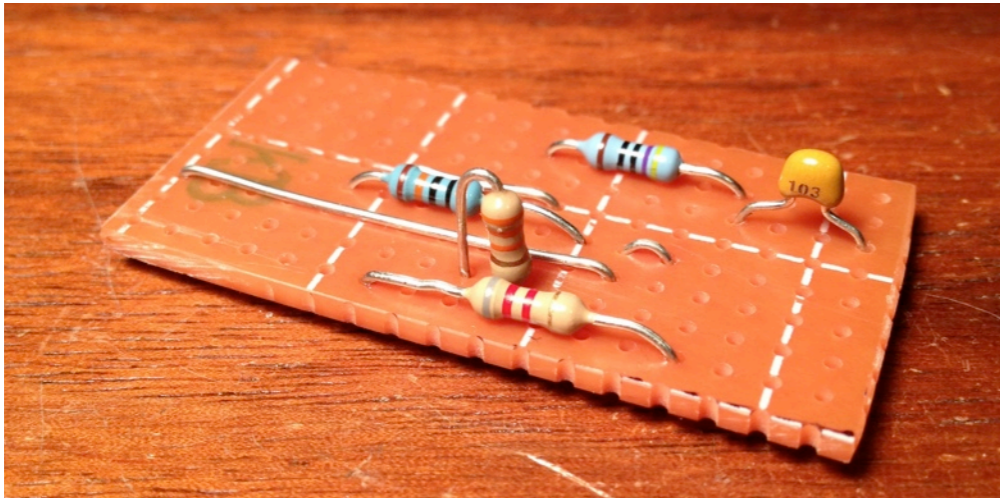

Solder a 47 $\mu$ f capacitor between rows A and C in column E. Note that this part is polarized and its **negative** terminal should be in row C. (The negative side is usually marked in a contrasting color, and the positive lead is usually longer.)

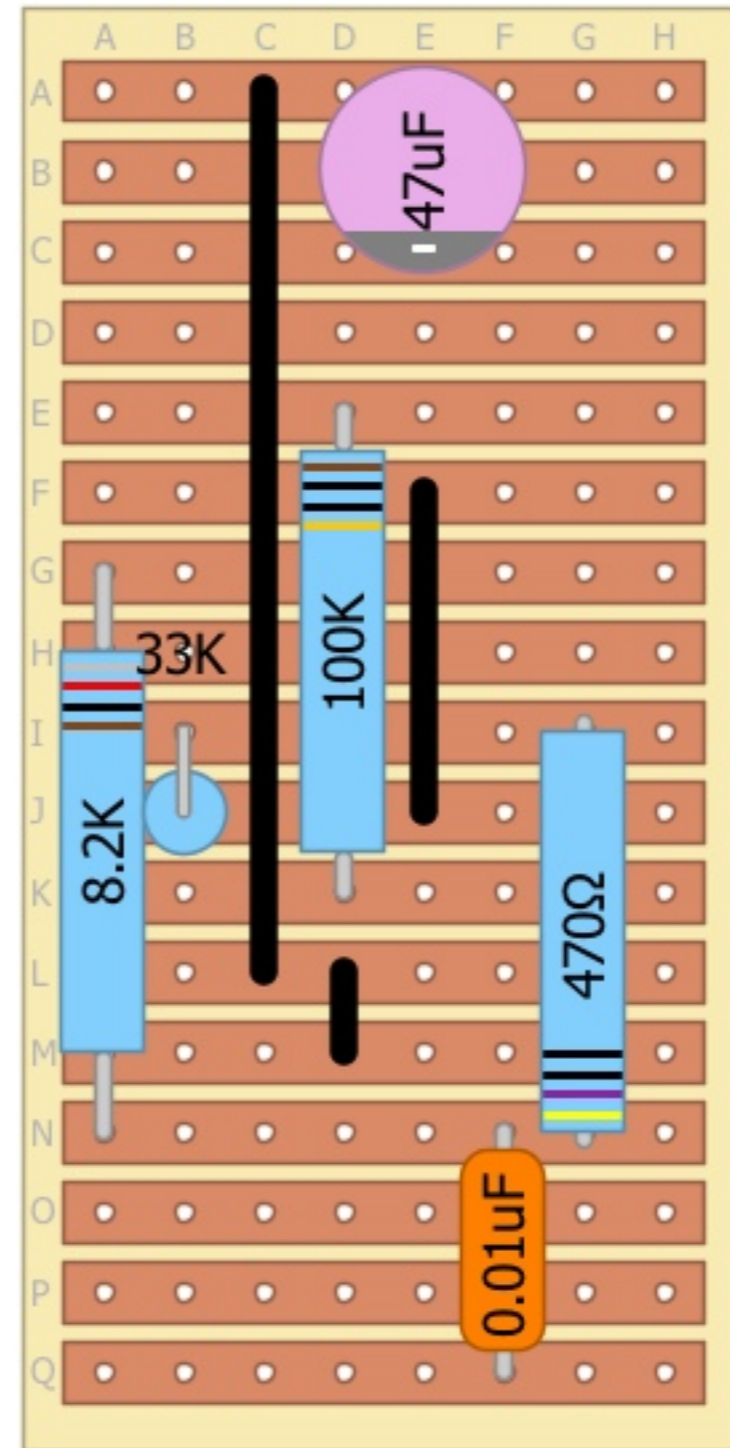
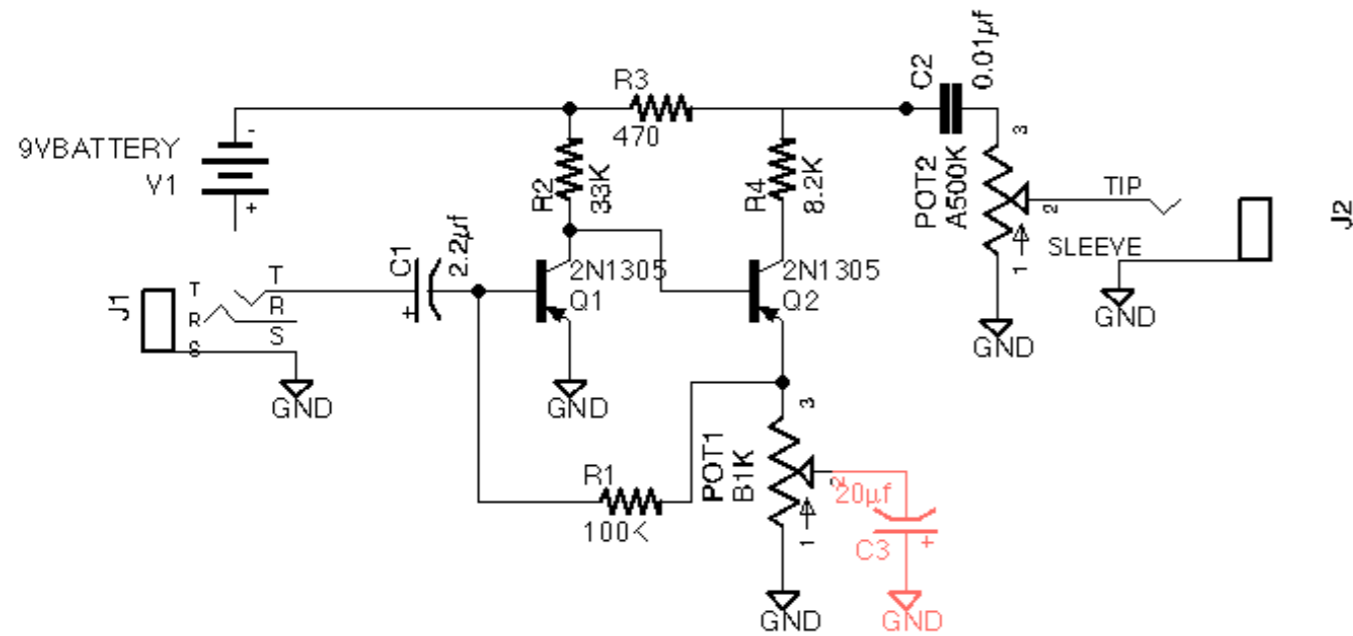
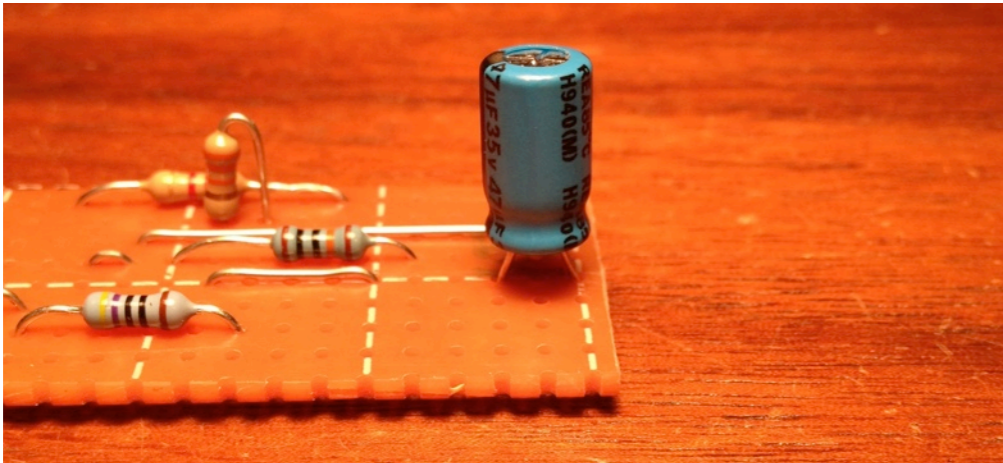

Solder a 2.2µf capacitor between rows H and K in column H. If this is a polarized part, the **negative** terminal should be in row K.

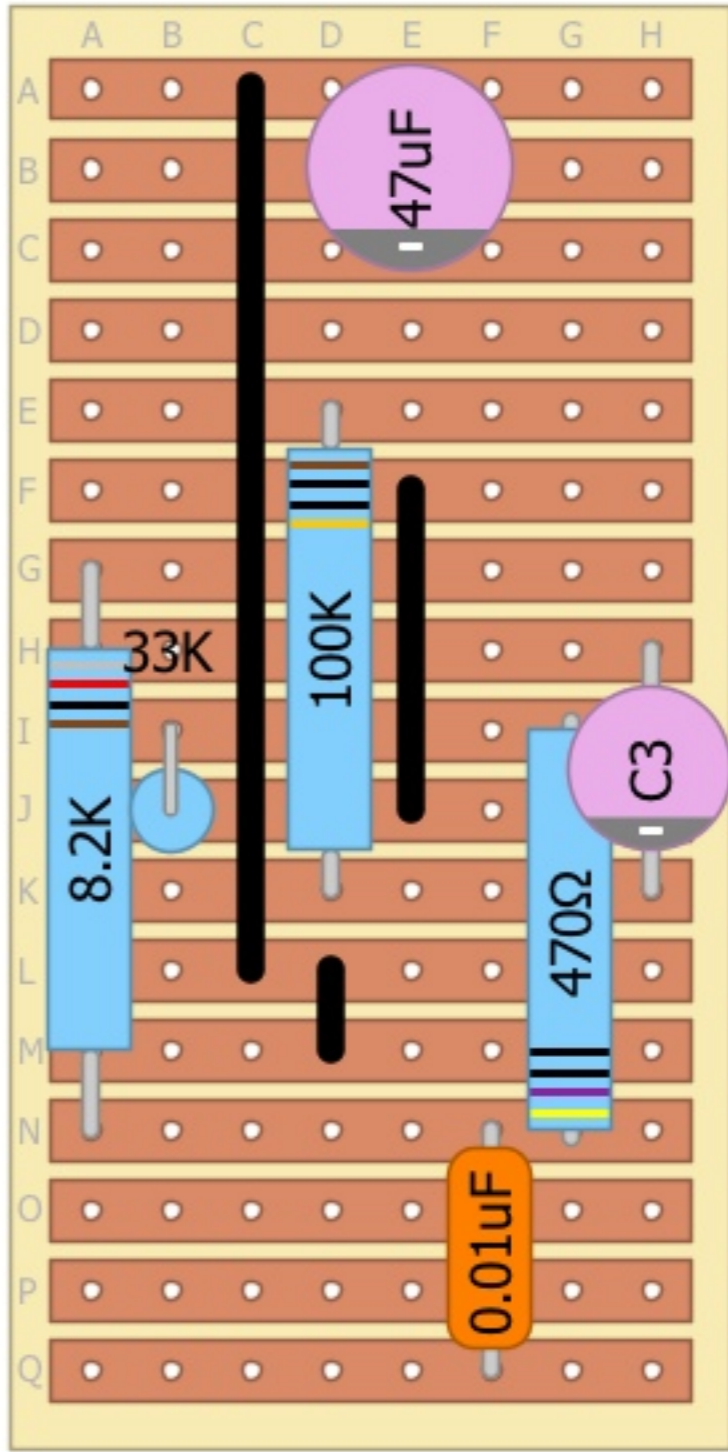
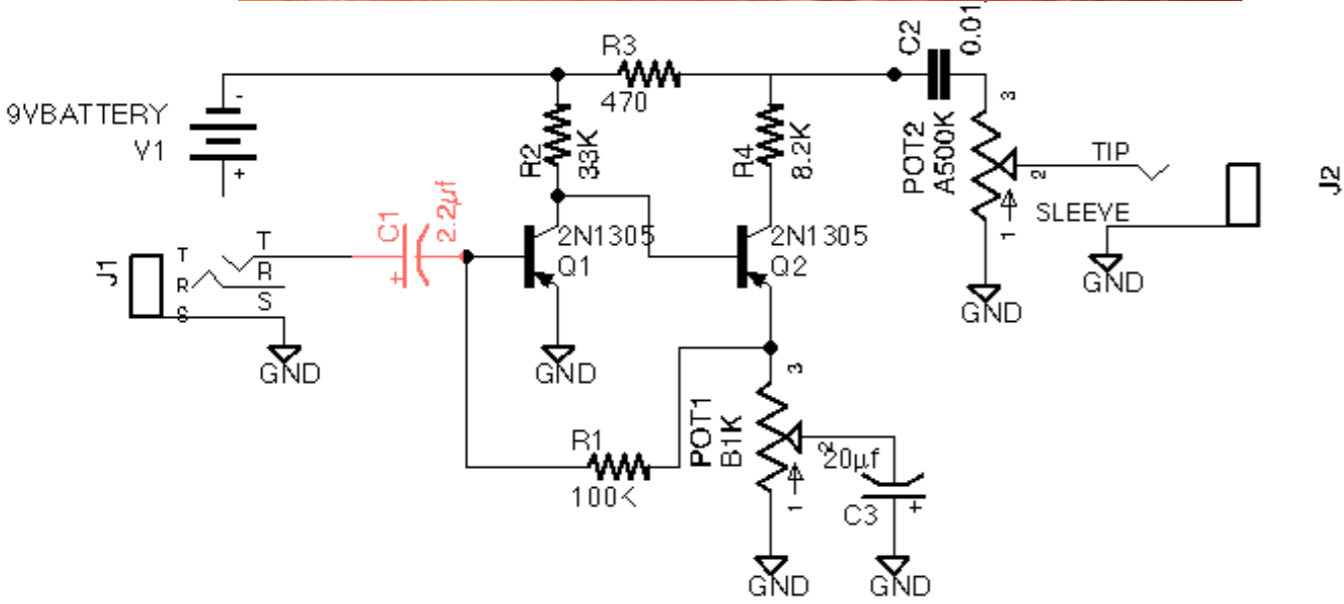
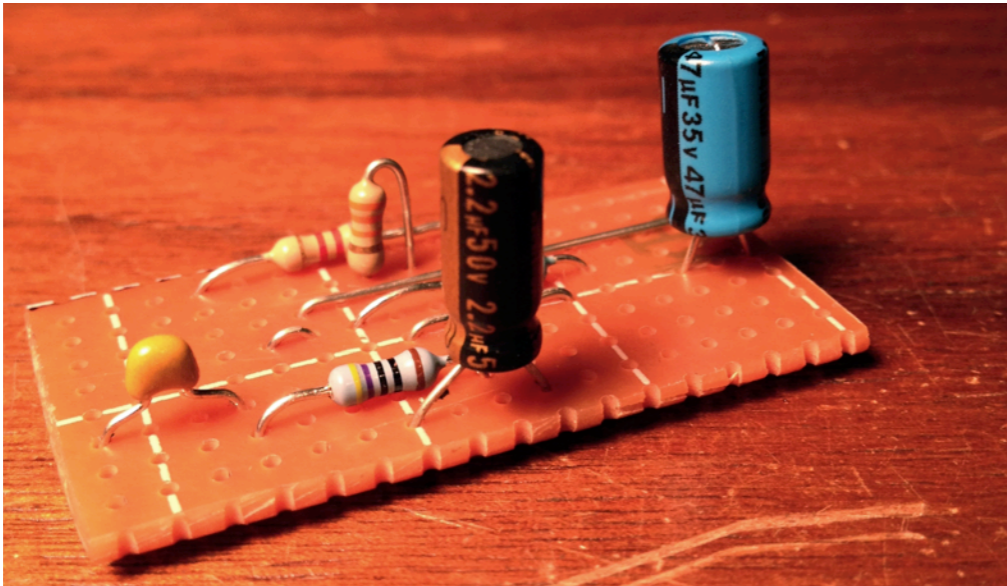

Solder Q2 in column F. This is a transistor with three terminals:

Collector: row G

Base: row F

Emitter: row E

**NOTE:** I recommend using socket here. That way, you can audition different transistors, and you run less risk of ruining this relatively costly component due to soldering errors. If you get a **strip of SIP socket**, just cut of a three-hole length and solder it in place.

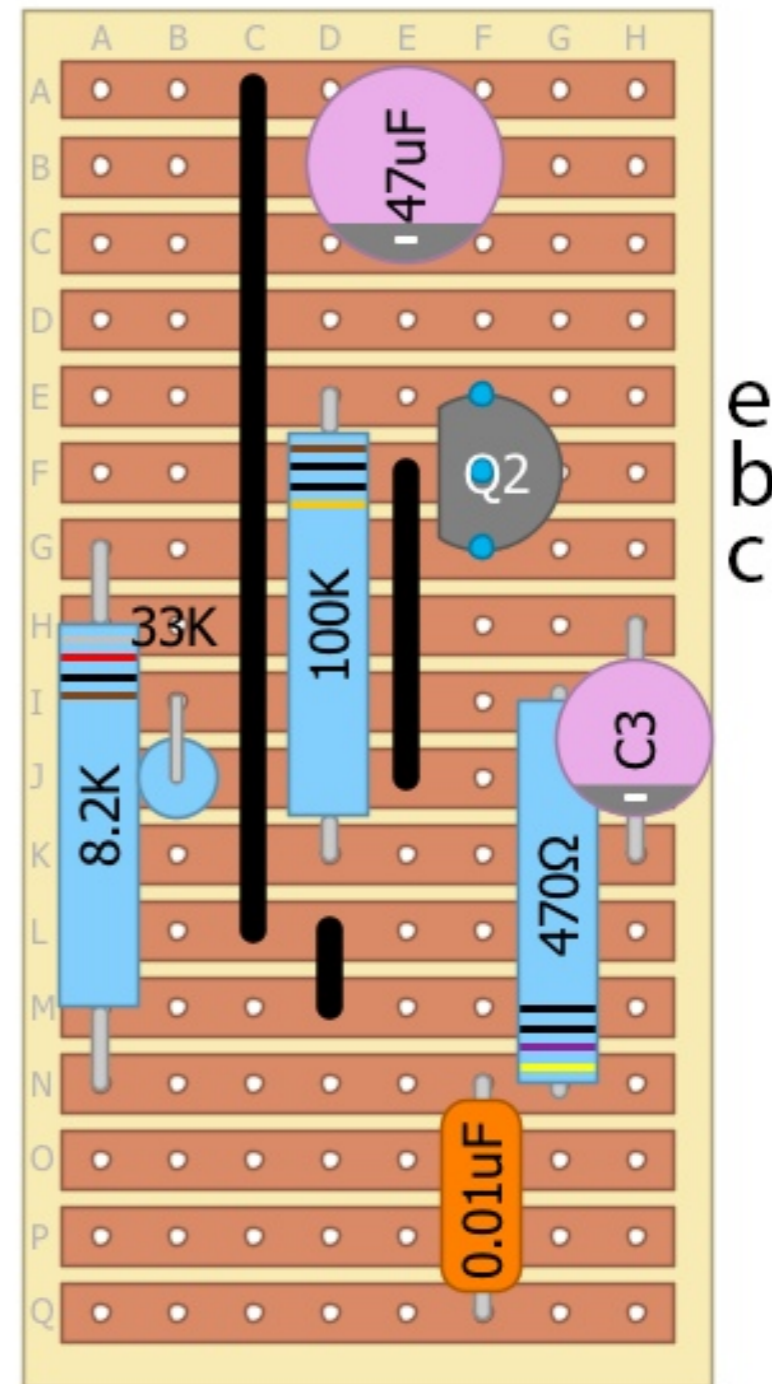
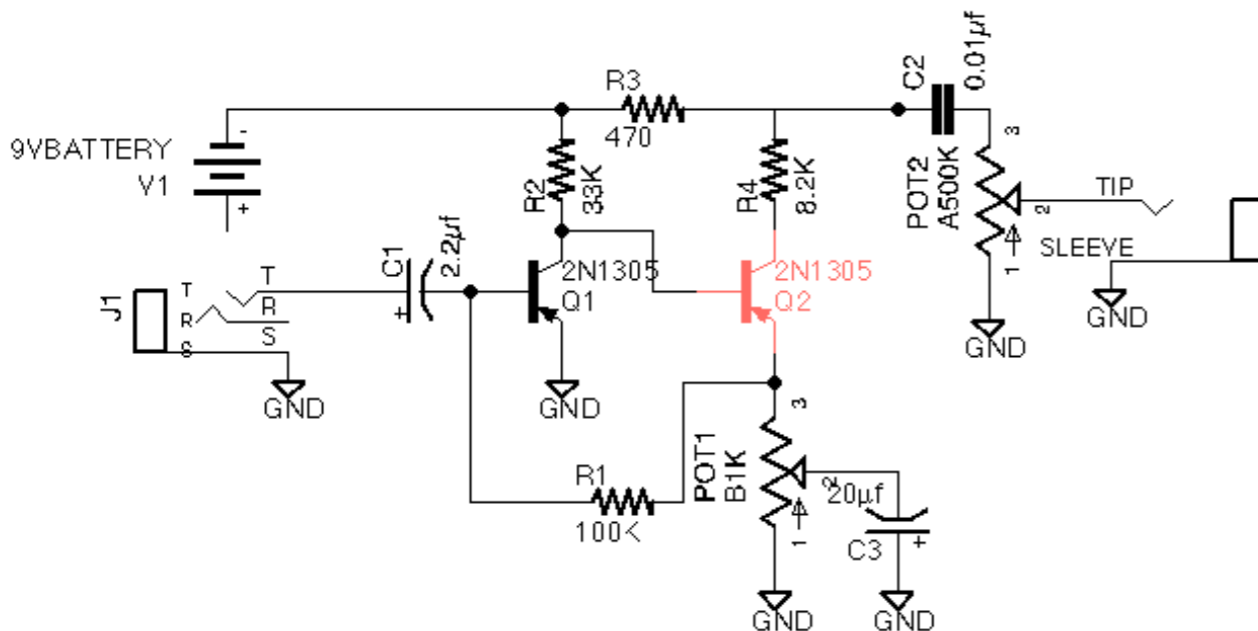

Solder Q1 in column F.

Collector: row J

Base: row K

Emitter: L

**NOTE:** I also recommend using a socket here.

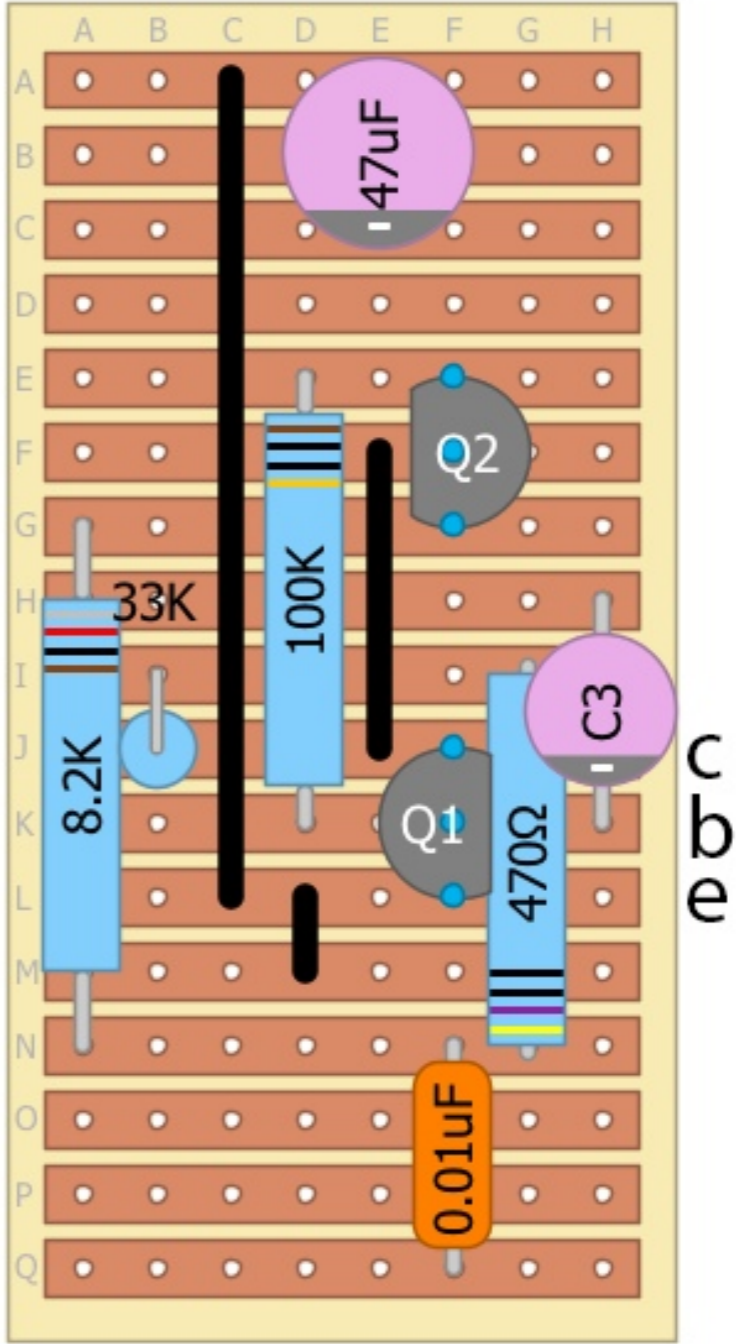
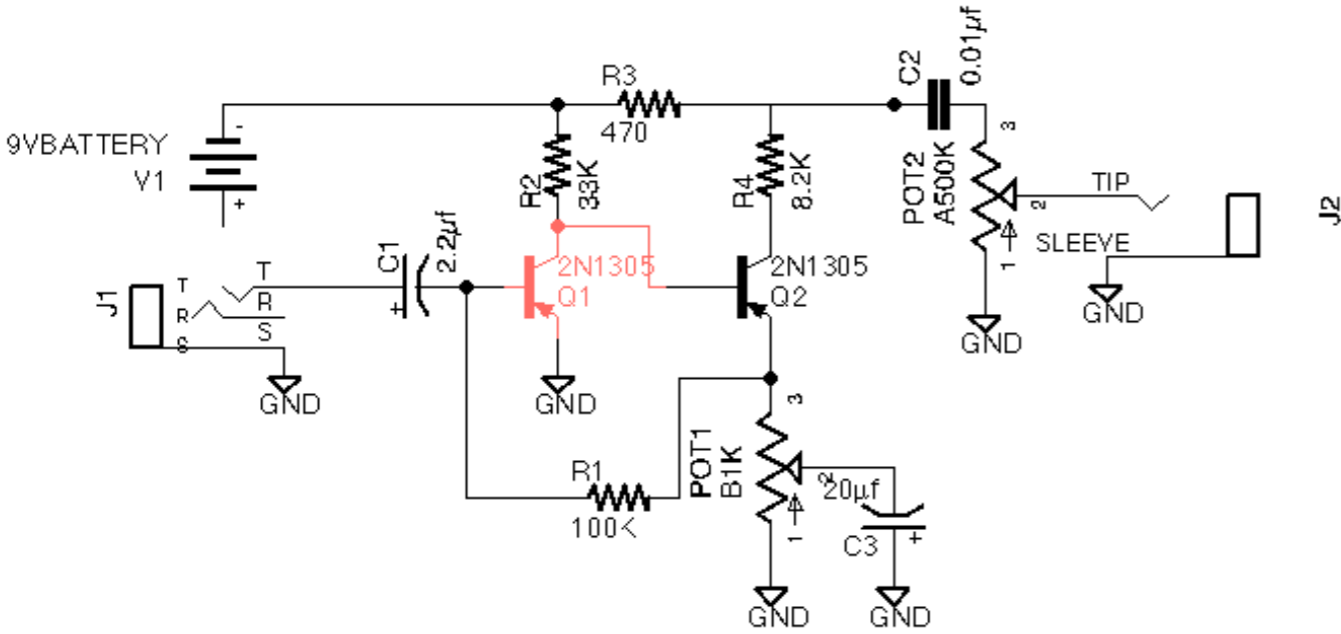

Cut a 4" piece of wire and solder to row A at column A.

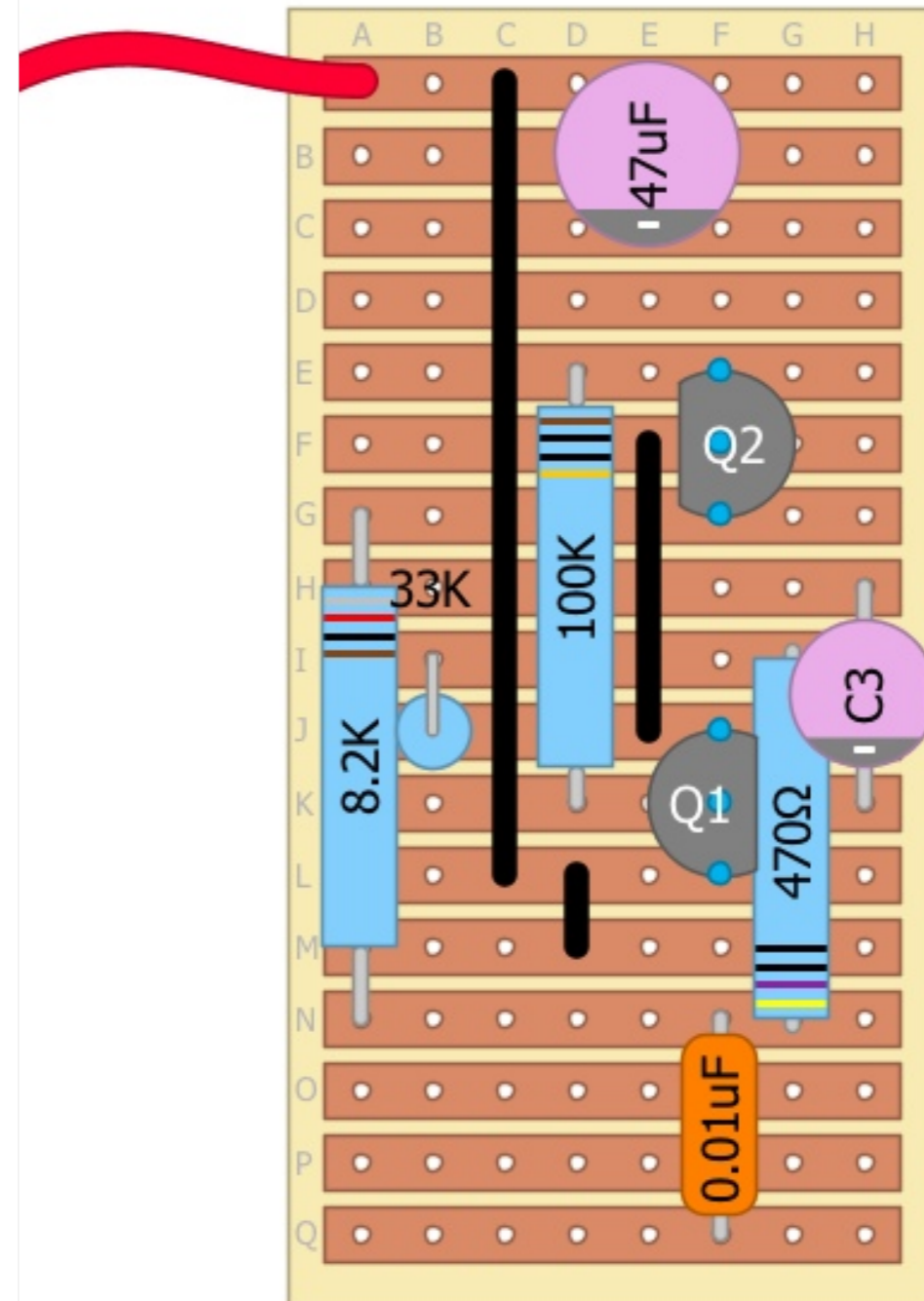

Cut a 4" piece of wire and solder it into row I at column F.

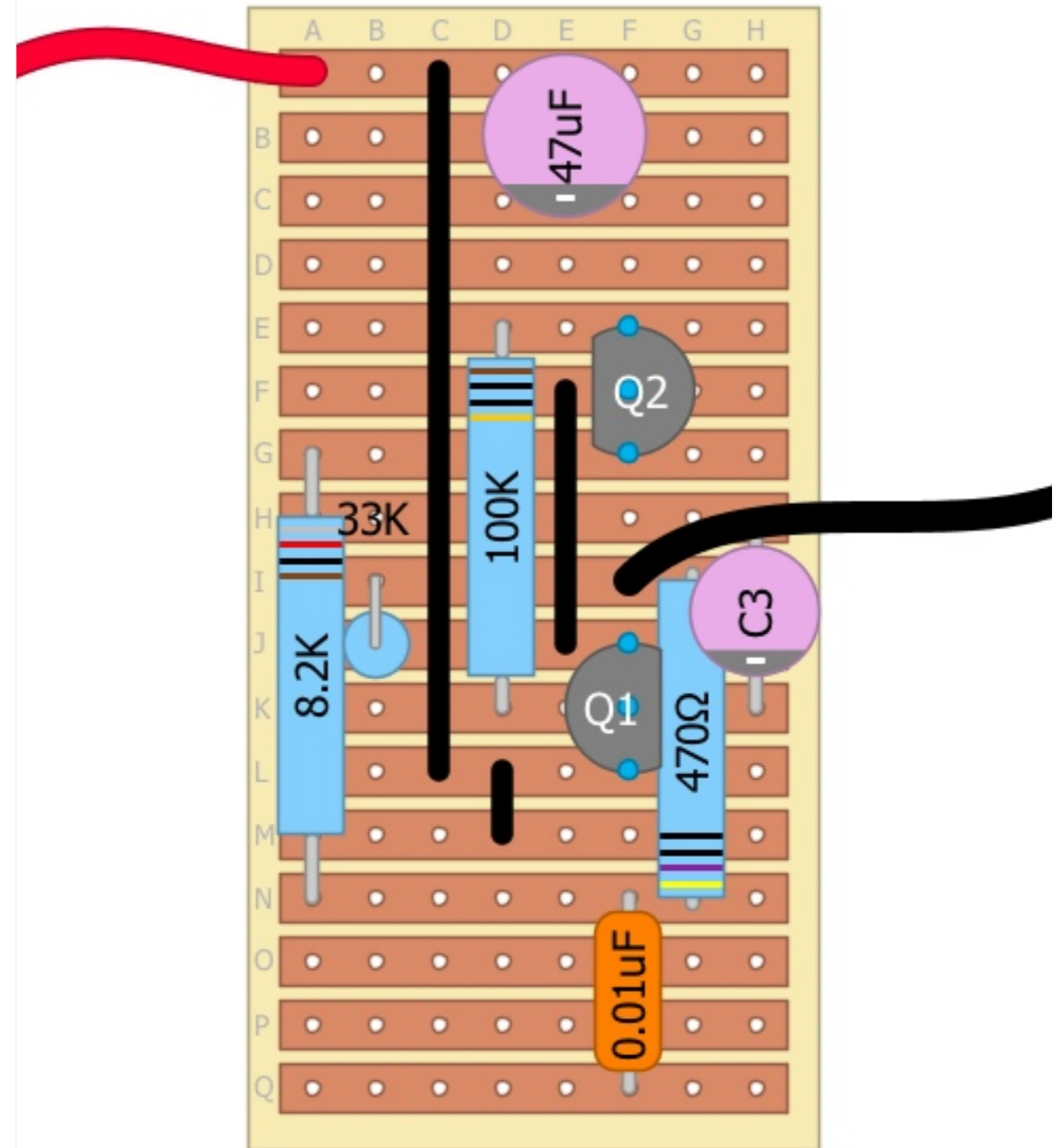

Cut a 4" piece of wire and solder into row H in column F.

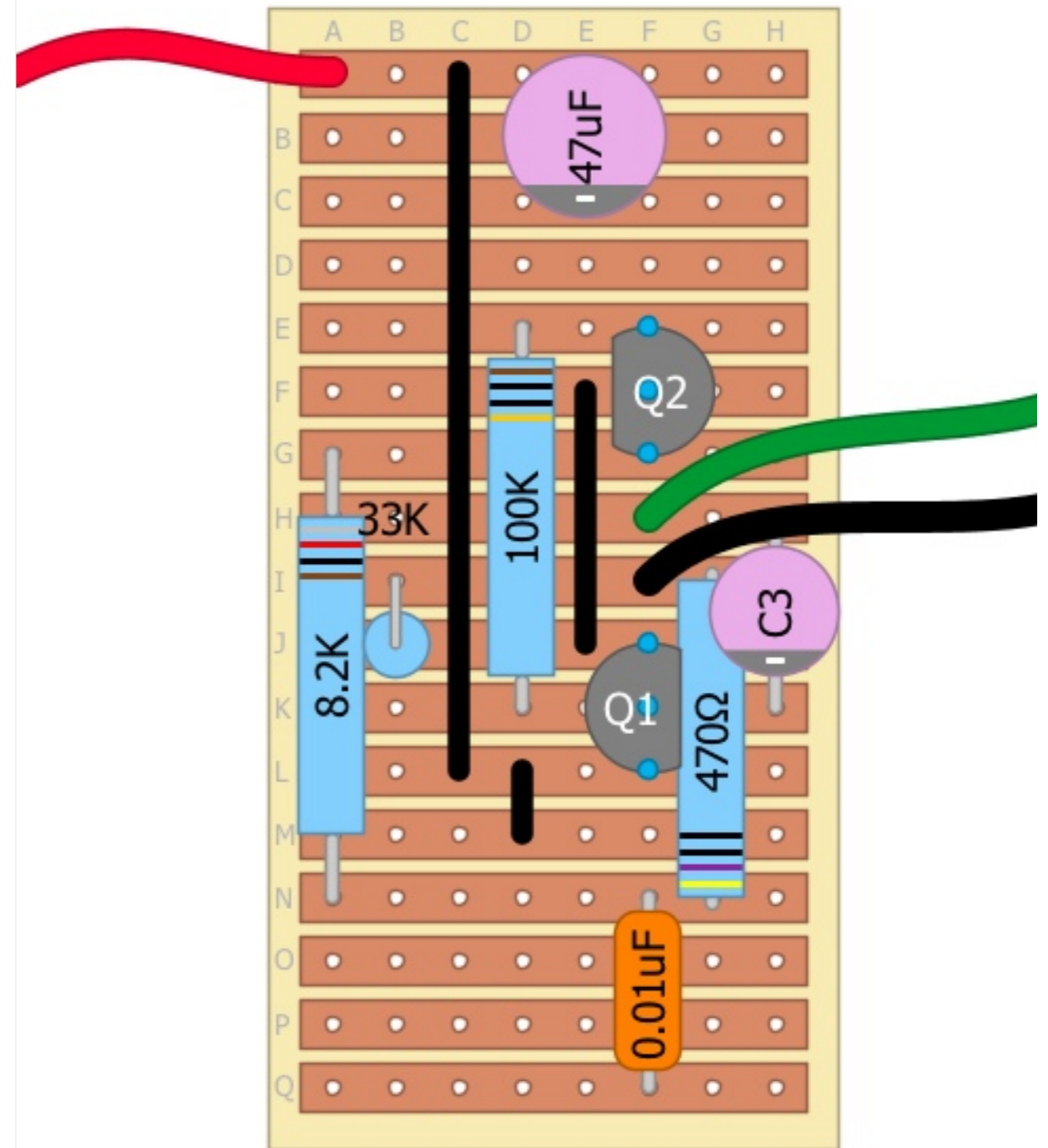



Cut a 4" piece of wire and solder it into row O at column A.

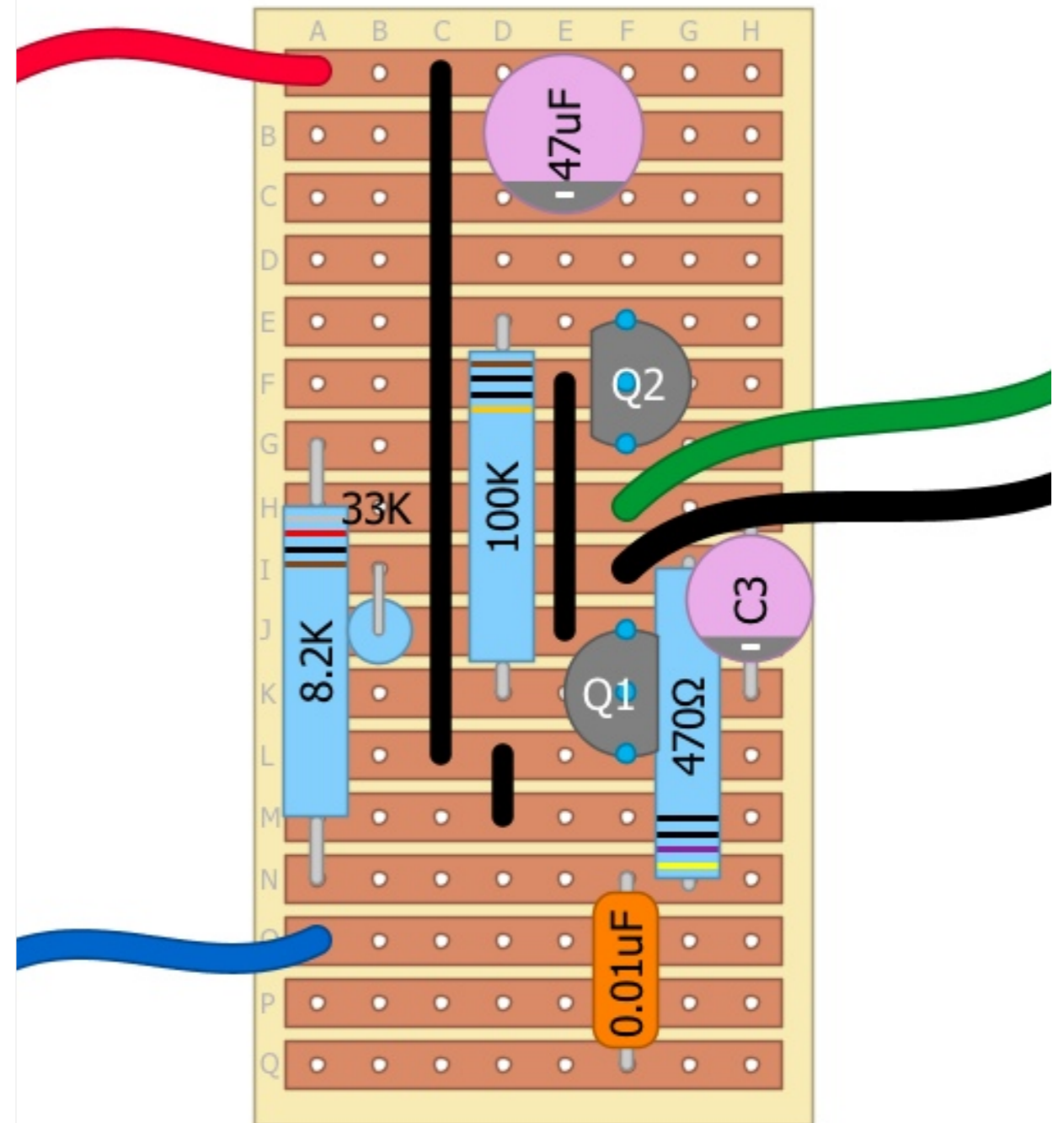

Solder the 1K pot to rows A, C, and E at column H.  
(If you use pots with lug-style connectors, solder three short lengths of wire into these holes, and then solder the other ends to the pot lugs.)

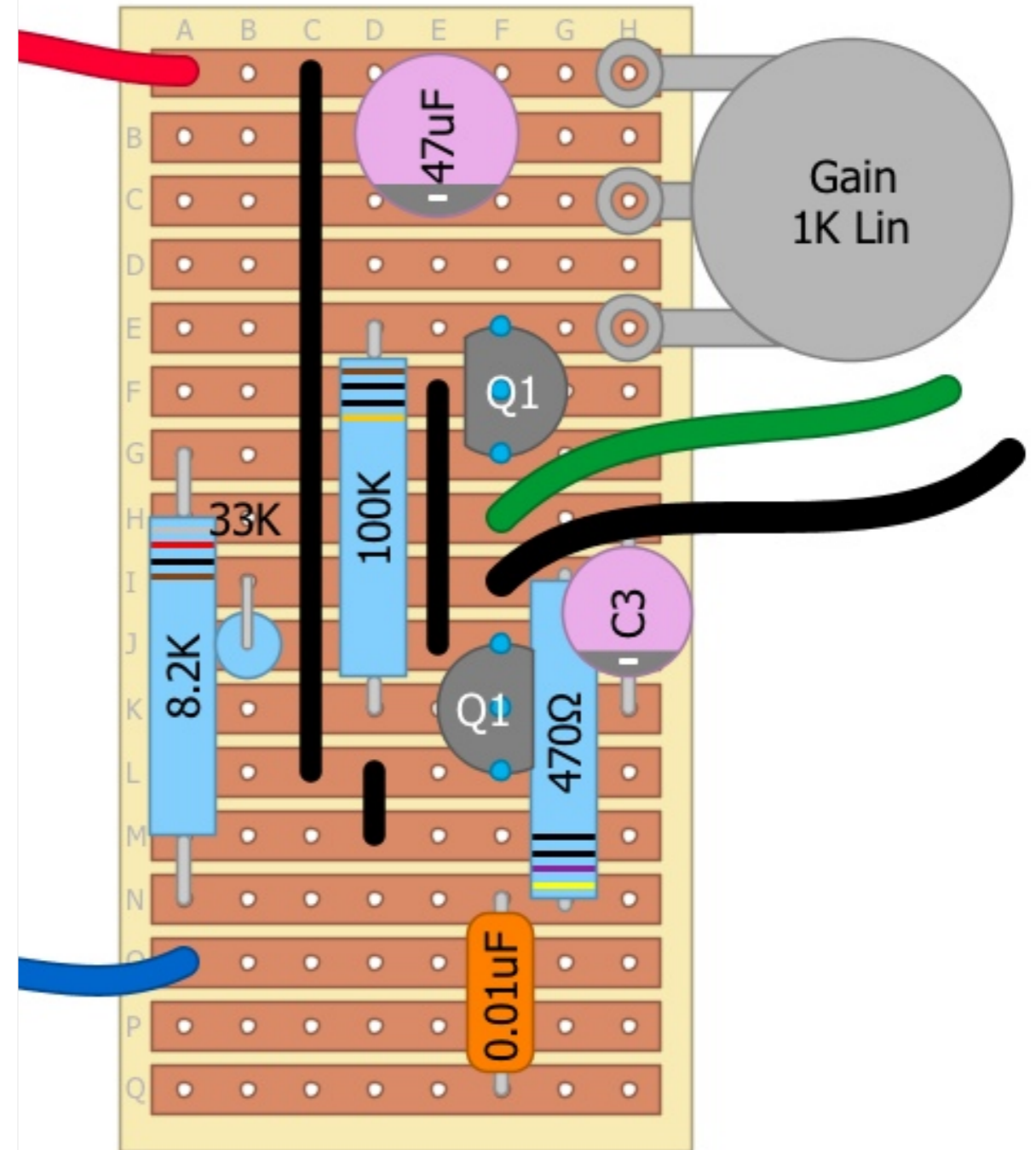
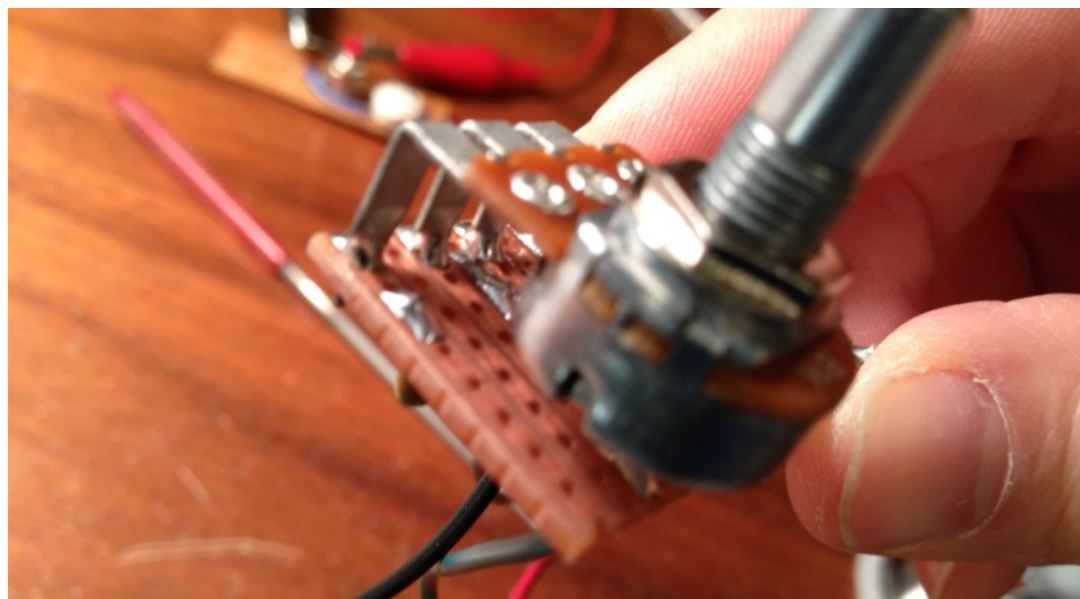
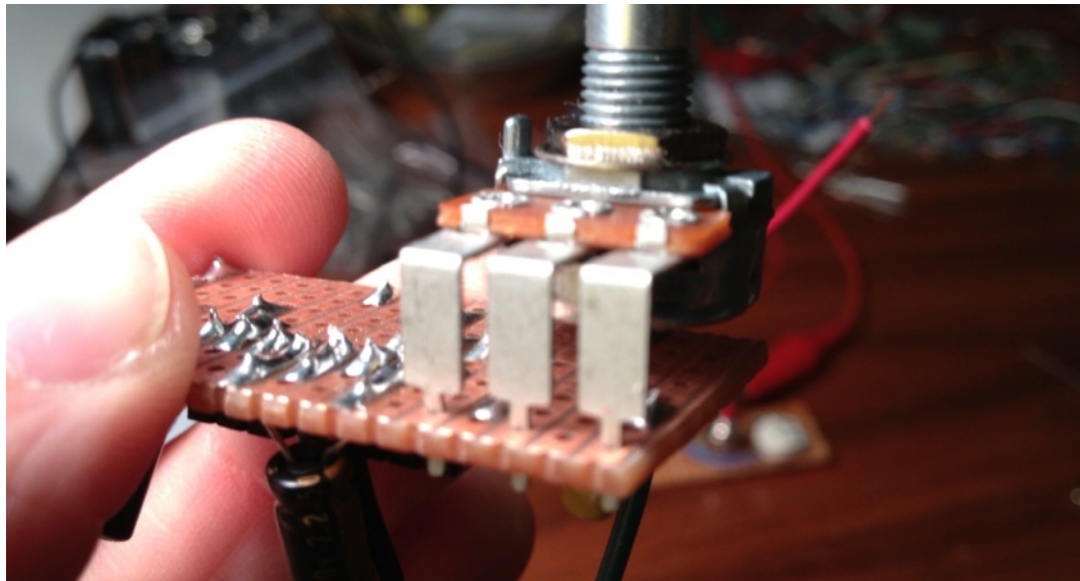

Solder the 500K pot with its terminals at rows M, O, and Q in column H.

**Note:** The more common 100K pot also works well.

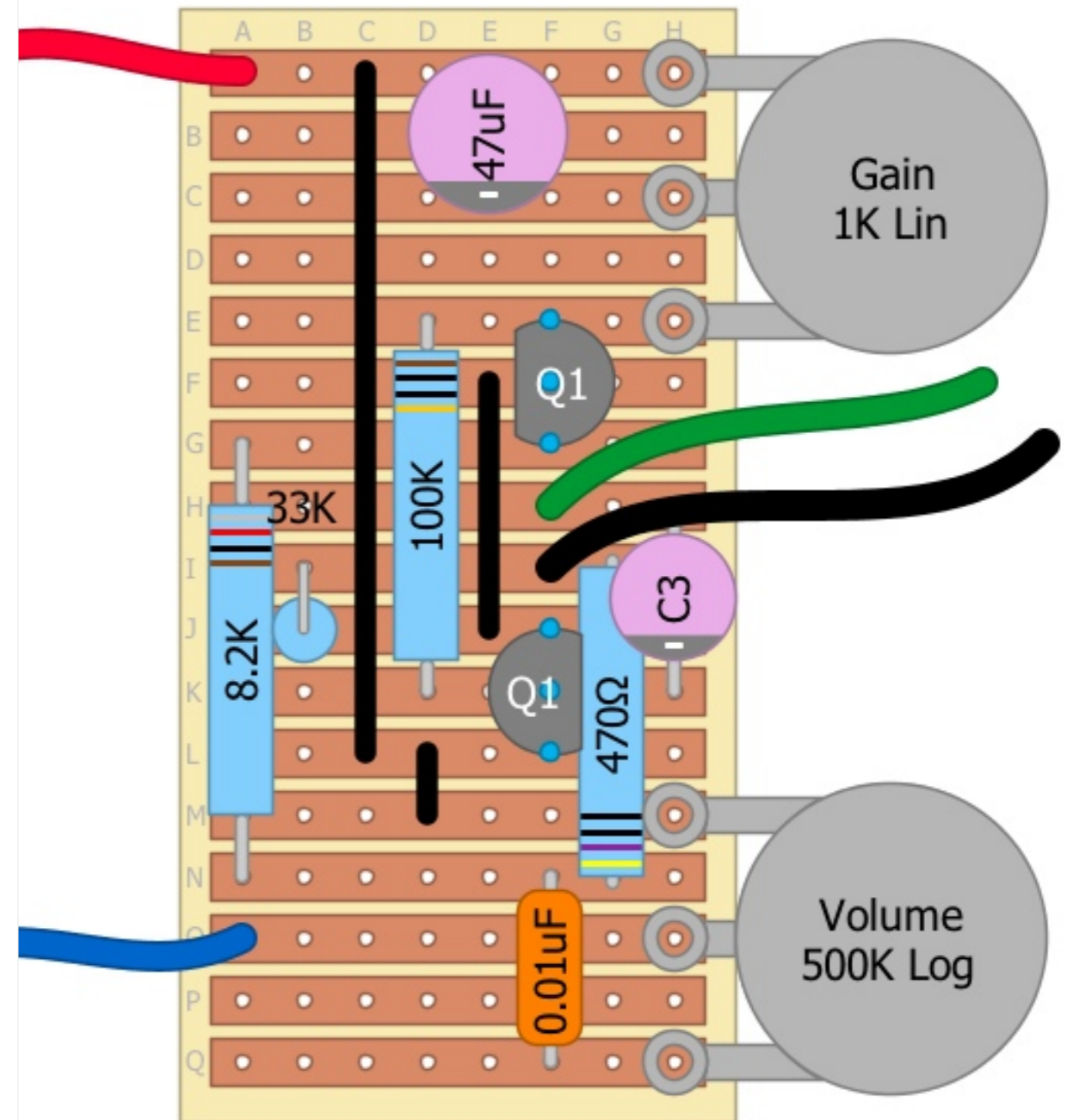

Here the wires are labeled. This is a PNP version that uses a positive ground.

When wired the red wire (+9V) connects to ground at the input jack.

**Remember, this is a PNP version and uses a positive ground. When wired, the red wire (+9V) will connect to ground!**

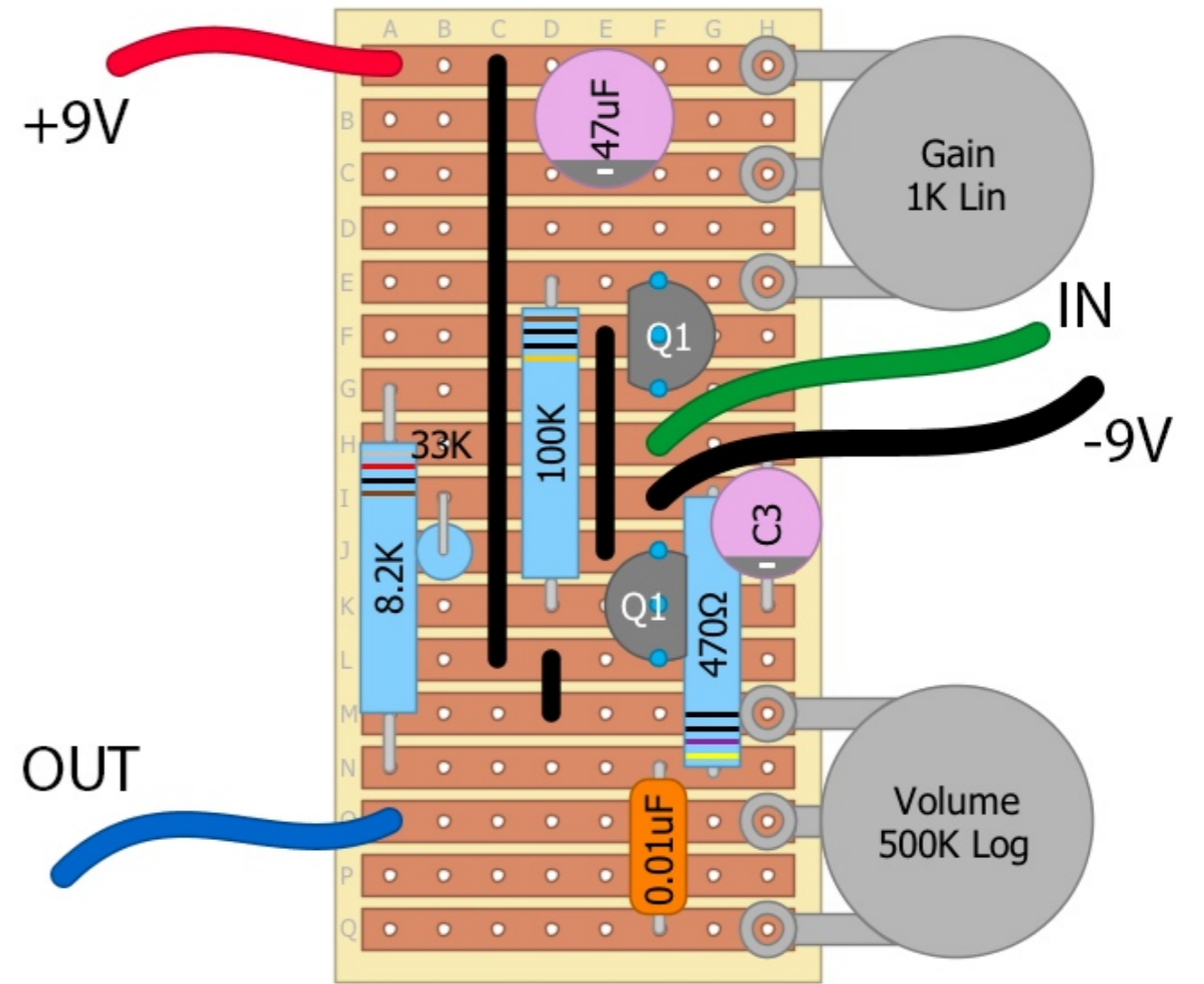

Here's my completed board. I used sockets for the transistors. I tested with two AC128 types. I'll need to cut down the leads before I box this up.

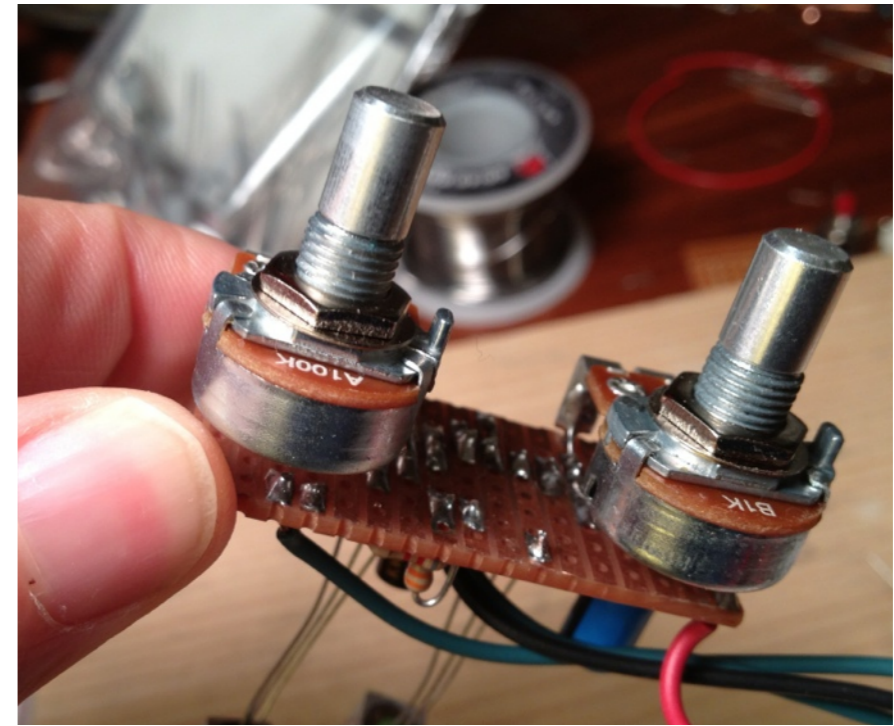
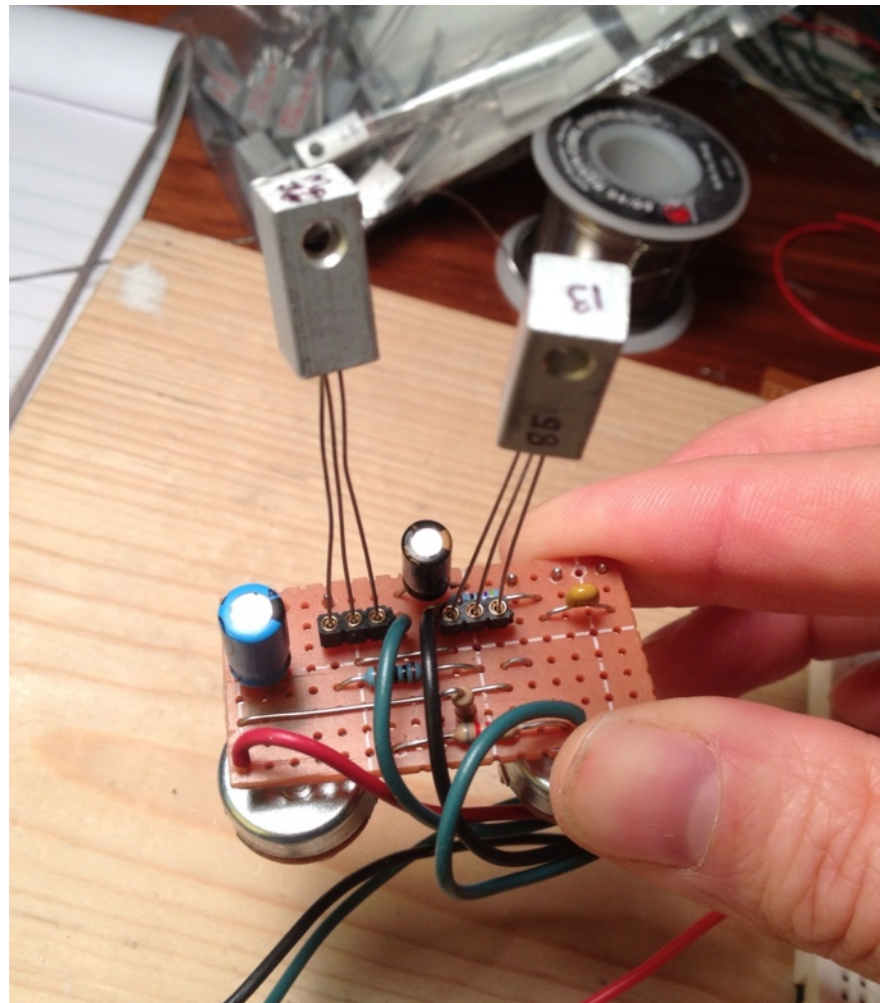

The post will hold the PCB in place.

You might drill the box to look like this. I measured the distance between the shafts on the two post mounted to the board then drilled the holes at the top of the box to the same distance. The large hole is for the switch and the smaller hole in the center is for the LED. (Omit the small hole if you don't plan to use an LED.)

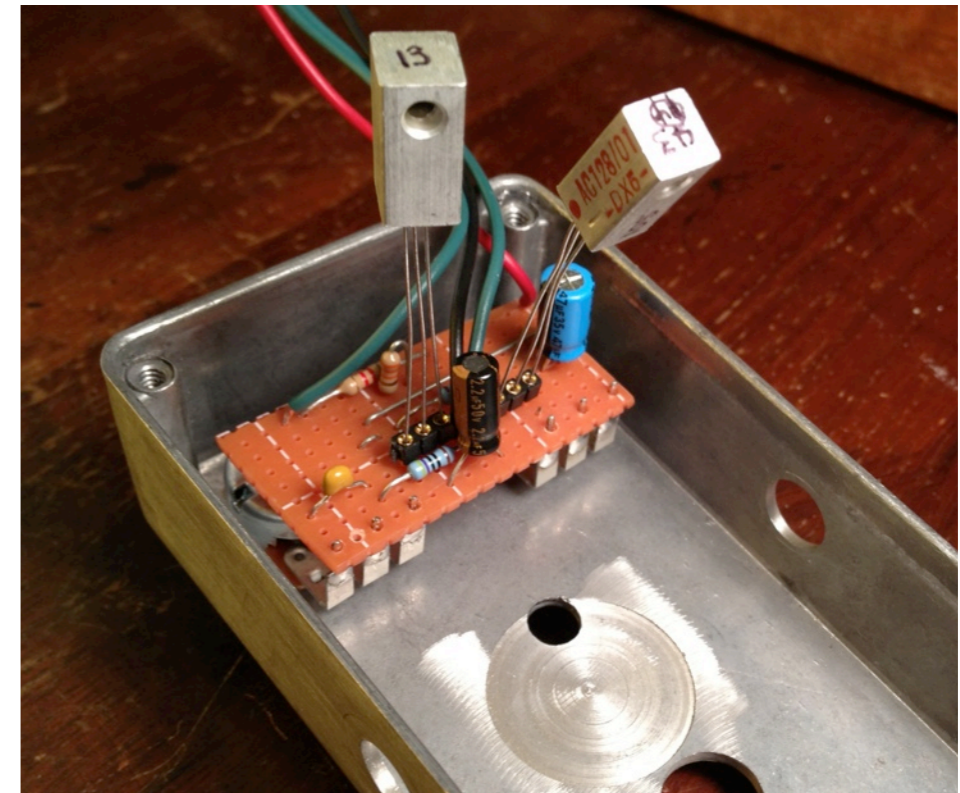
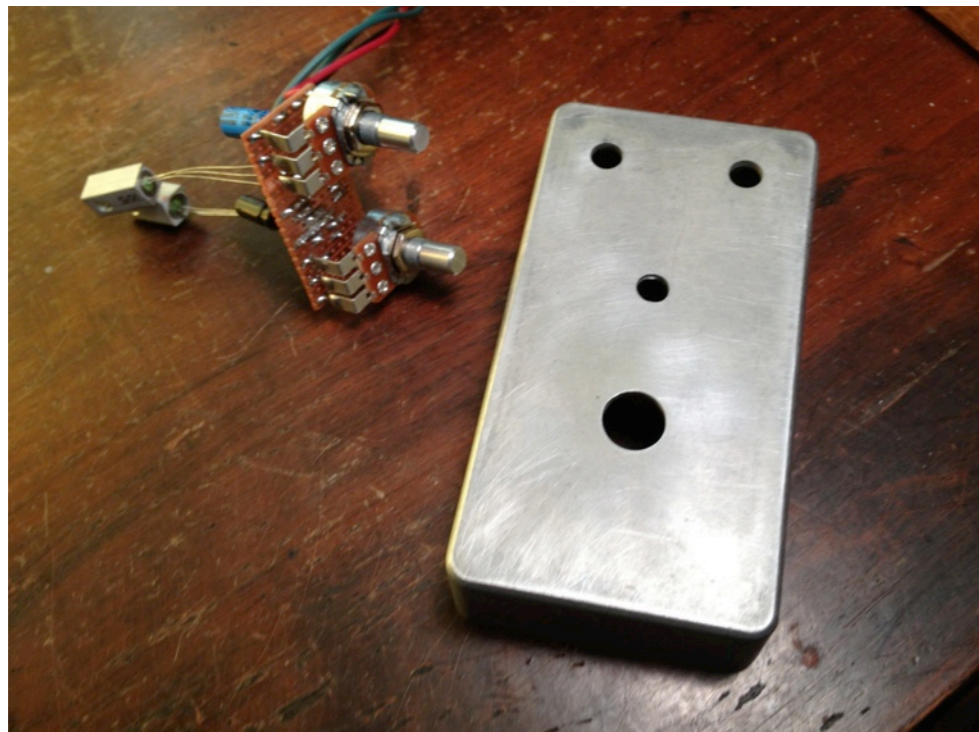

The inside might look like this. After testing these transistors I'll cut their leads shorter and tuck them in the box.



# Boxing the Fuzz Face

The Fuzz Face is easy to box up. There is no DC jack, since the effect uses a negative power supply. This makes the wiring a little different than when using modern negative-ground wiring.





I drilled a blank box, and then mounted the switch, LED bezel, and input and output jacks. Here's what my box looks like.

Since the pots are mounted the board, the hole position is important. The two posts are 1.2" apart. (If you're not using board-mounted pots, you have more wiggle room, but be careful not to drill too close to the edges of the box, or there may not be room to accommodate the pot.)

The second picture shows the parts mounted in the box from underneath. Notice the lugs on the switch are parallel across the narrow width of the box.

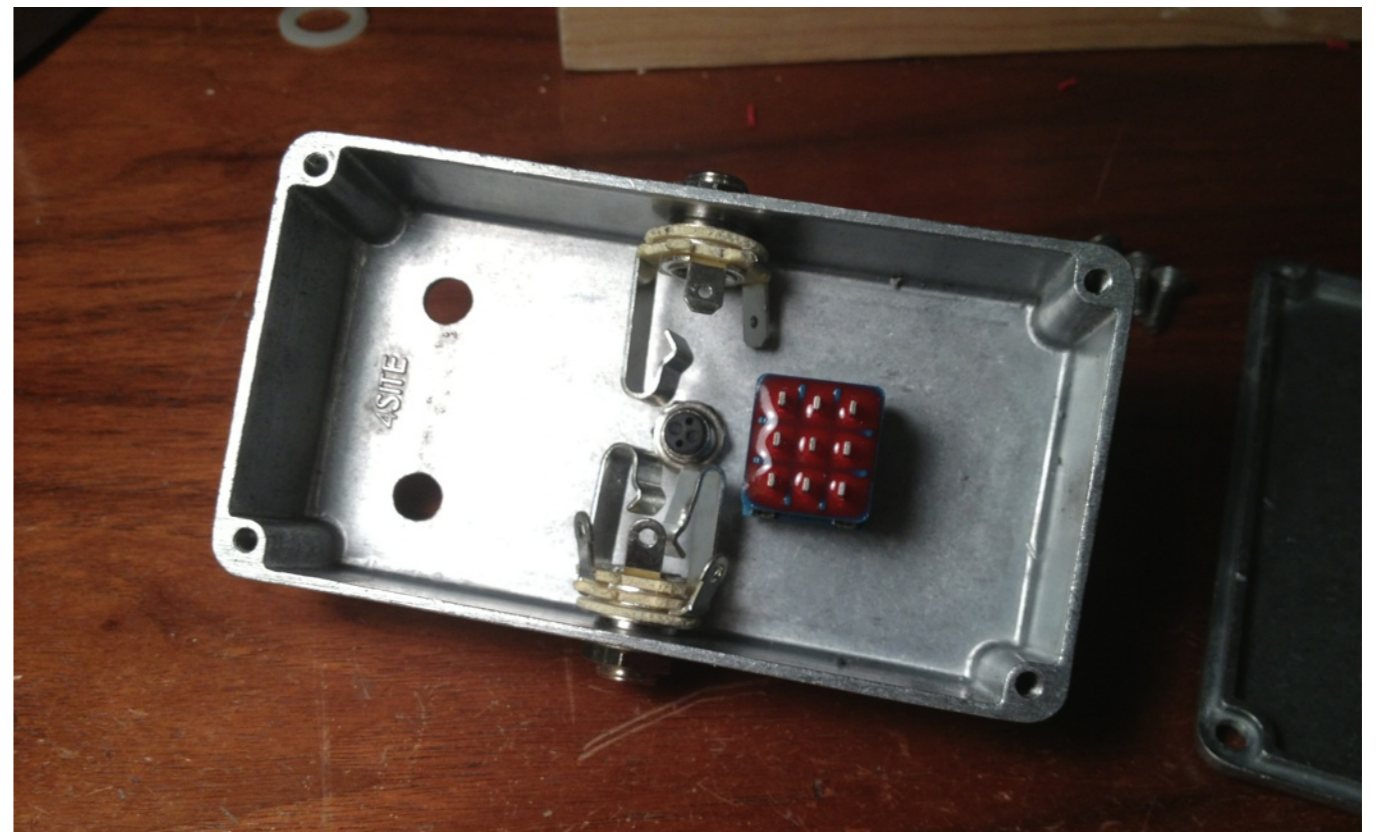
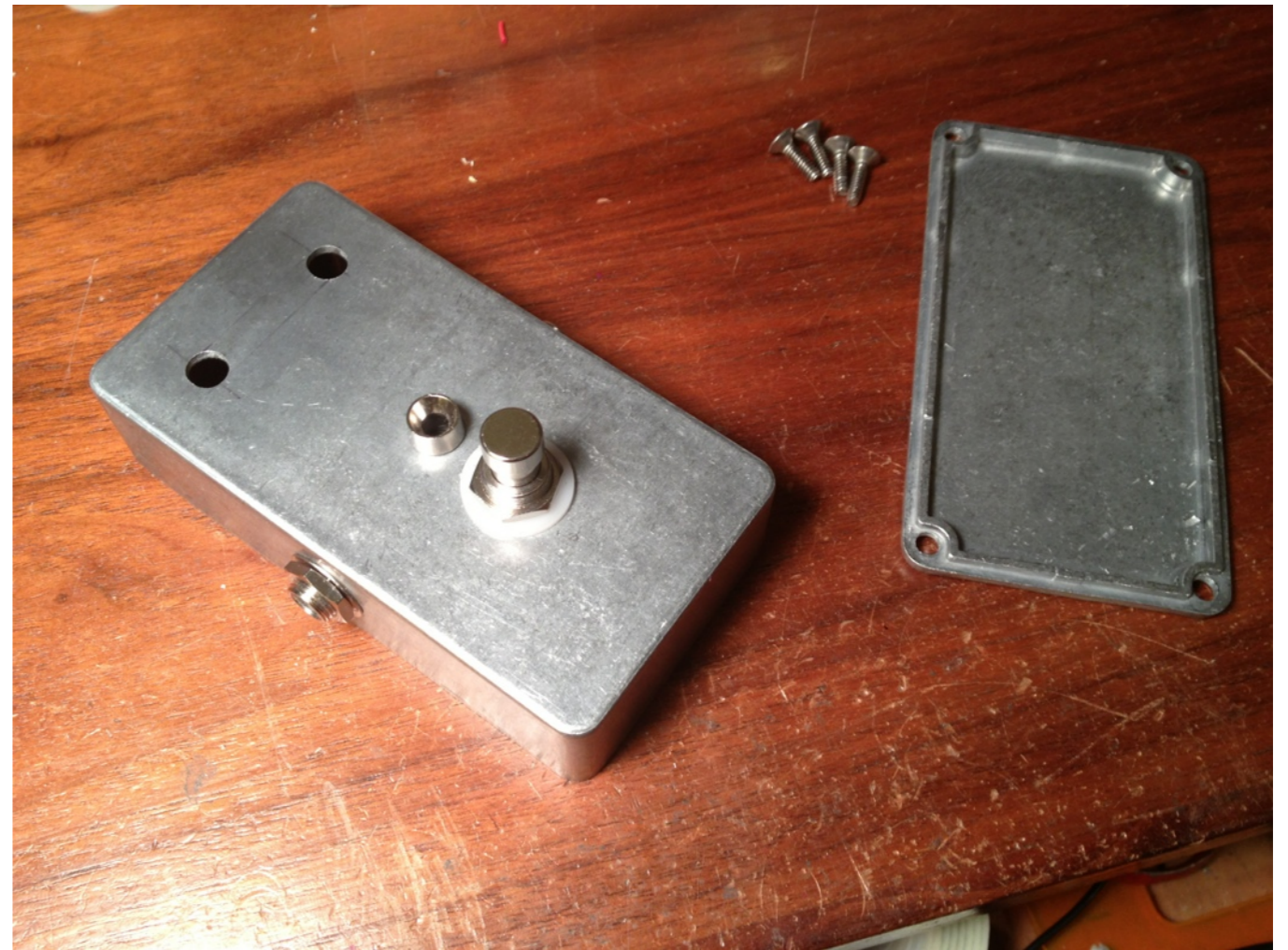

You'll need to remove the tabs from the sides of the pots. Just snip them off with a wire clipper.

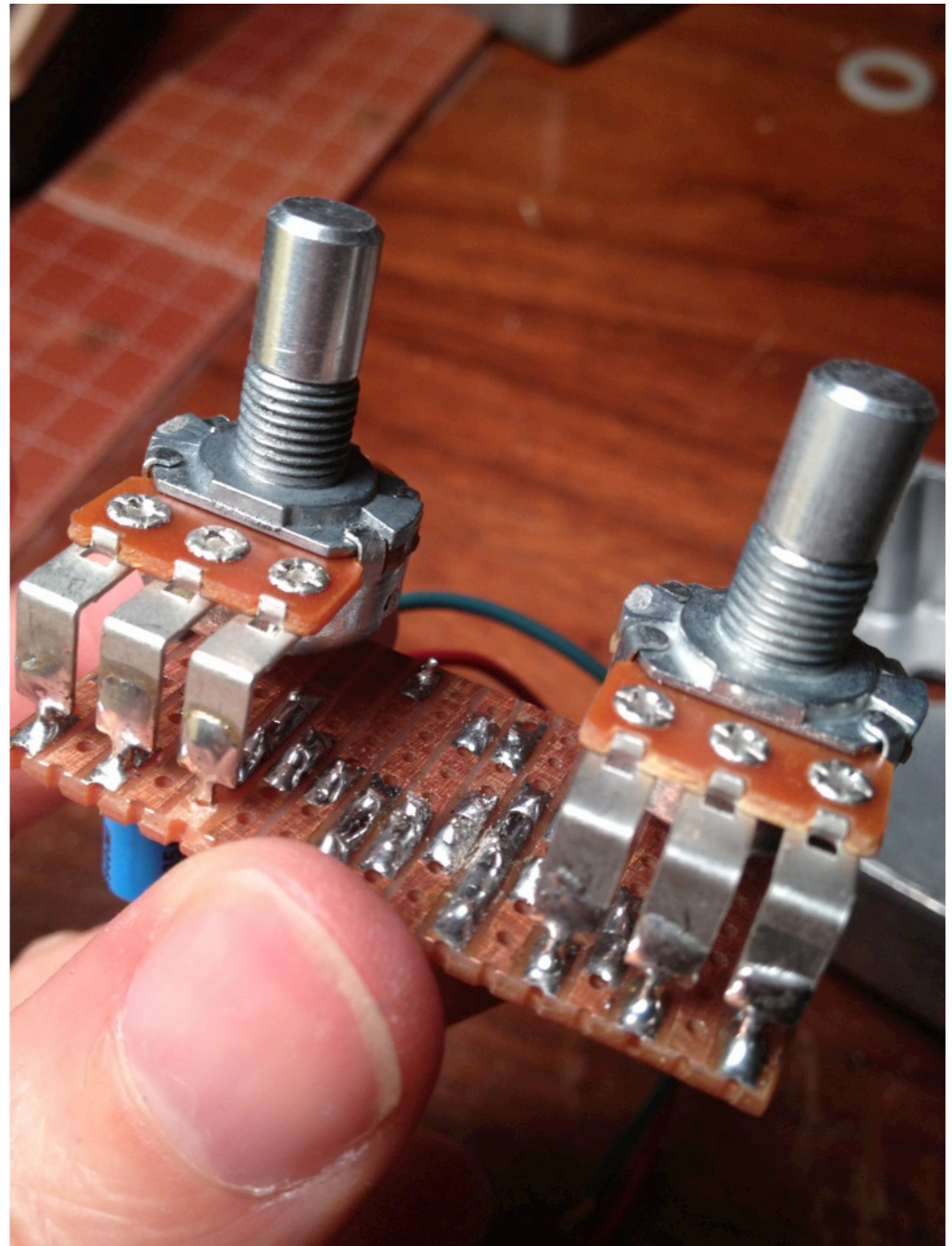
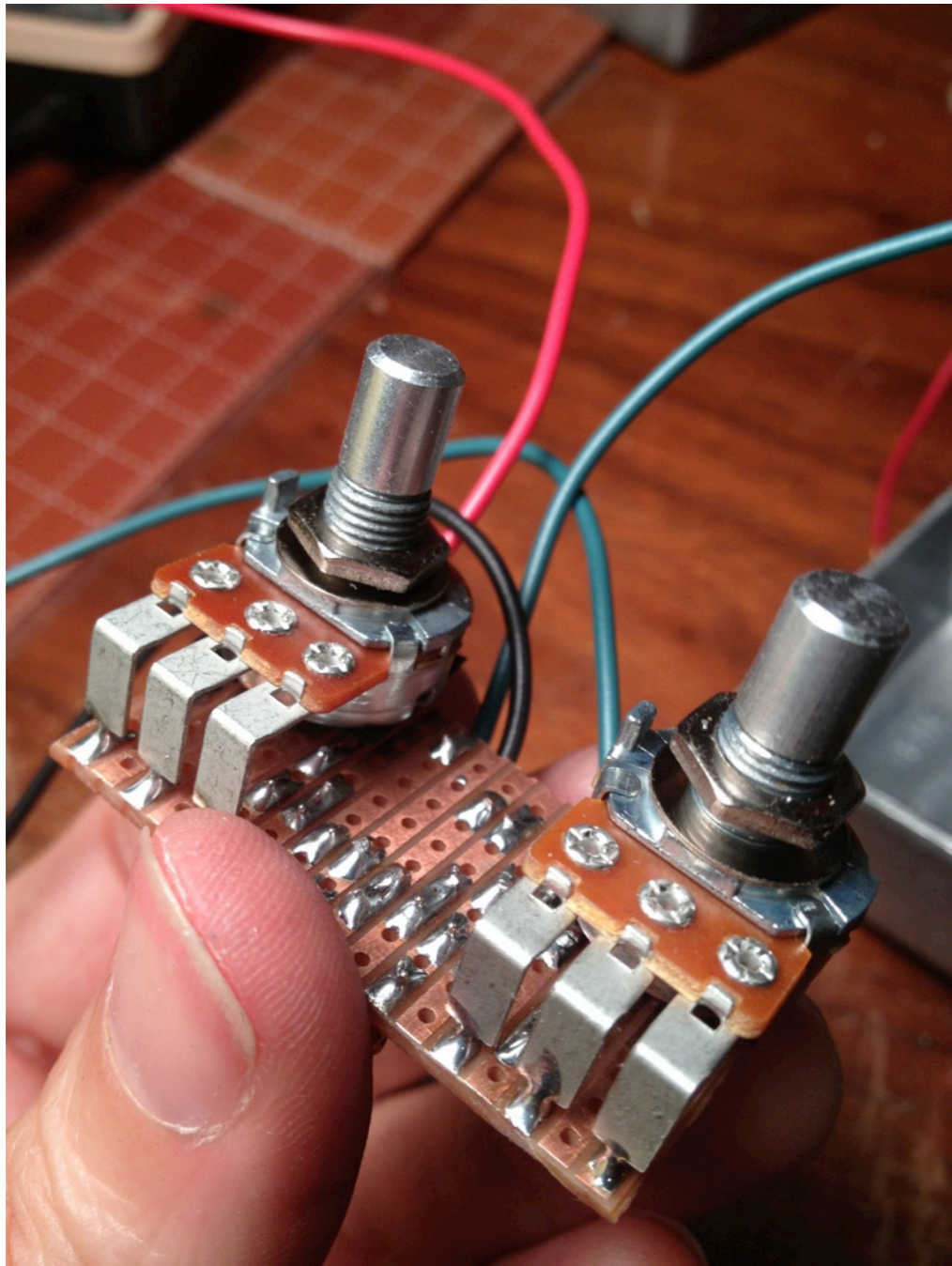

Mount the PCB board to the box. (If you're not using board-mounted pots, use double-sided adhesive tape to secure the board.)

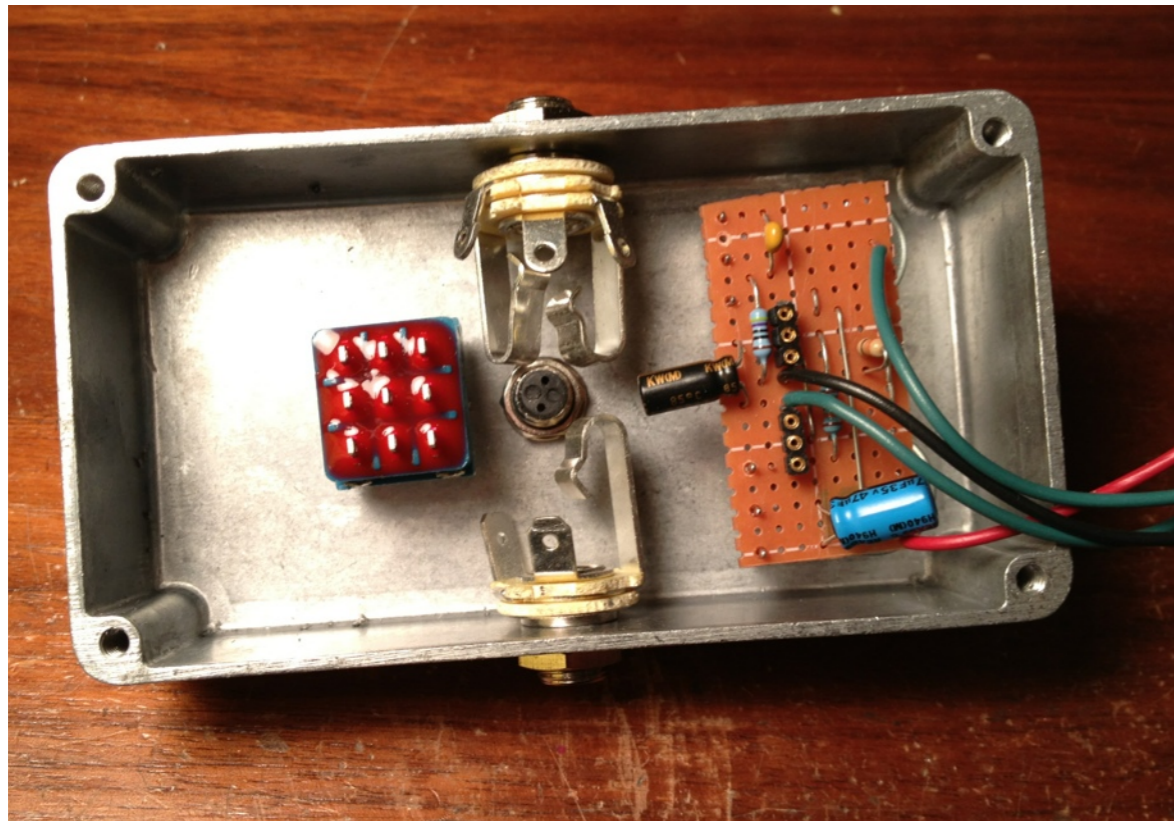

Attach the pots' screws, securing the board in place.



Solder a short length of wire between the lower left and lower middle footswitch lugs. Snip of any excess length.

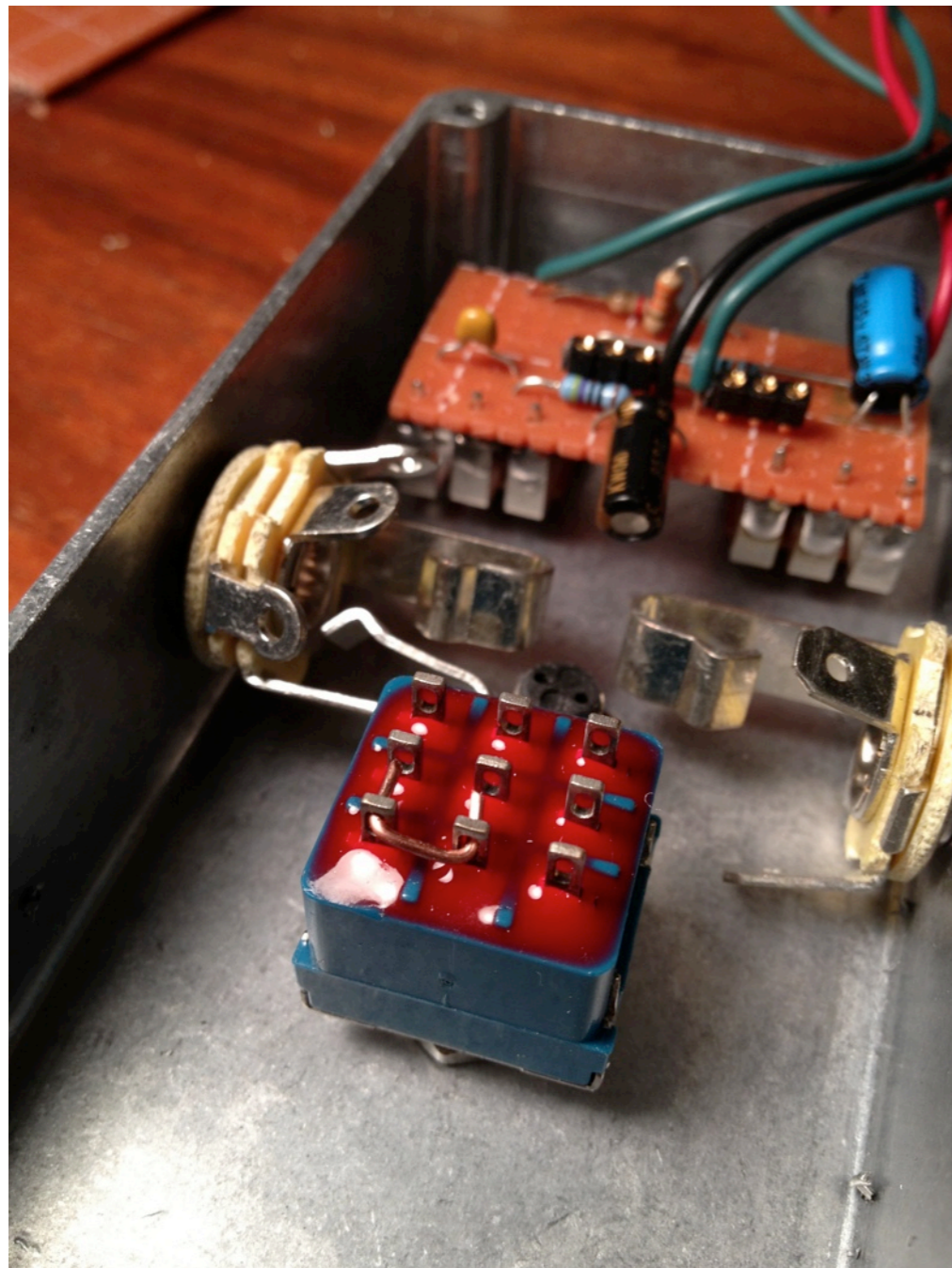

Run a short length of wire between the footswitch's upper-left and lower-right lugs. Solder it into the lower-right lug, but **don't solder it into the upper-left lug just yet.** Keep the insulated coating on this wire so the wire doesn't touch any lugs other than these two.



Solder a short length of wire to the input jack's outermost lug (the ones closest to the side of the box). Solder the other end to the upper-left lug, together with the wire previously placed there. (You don't necessarily need to thread both wires *through* the lug, so long as the two are securely soldered to this point.)

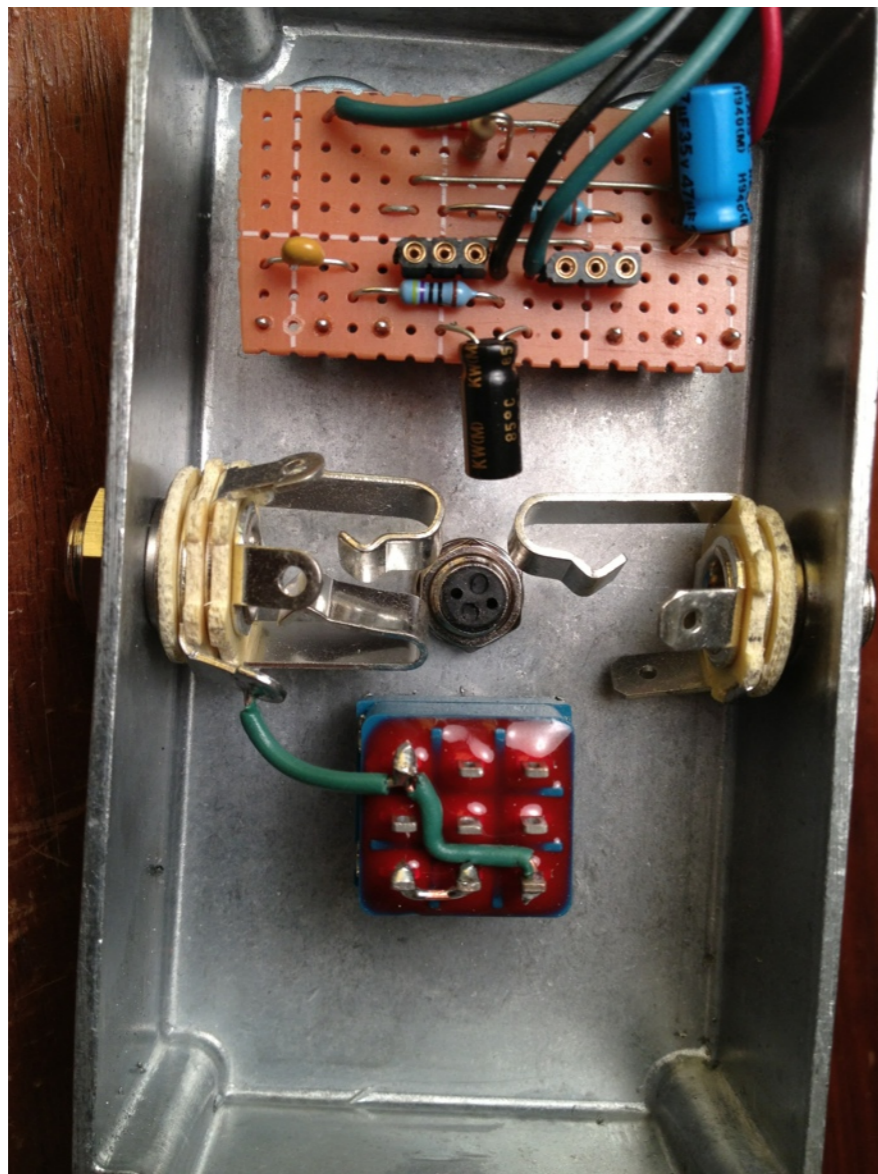

Solder a short length of wire between the output jack's outermost lug (the ones closest to the side of the box) and the center-left footswitch lug.



Work the LED's leads through the holes in the rubber stopper. The longer lead is the positive connection. (You can also omit the LED altogether if you like.)

The LED has a long and short lead. The long lead should connect to the more positive supply.



Press the LED and stopper into the LED bezel, securing them in place.

Position the LED so the longer lead is closest to the switch. Solder the longer lead to the center tab of the switch. You can insulate this or solder a wire to extend it if the lead from the LED isn't long enough.

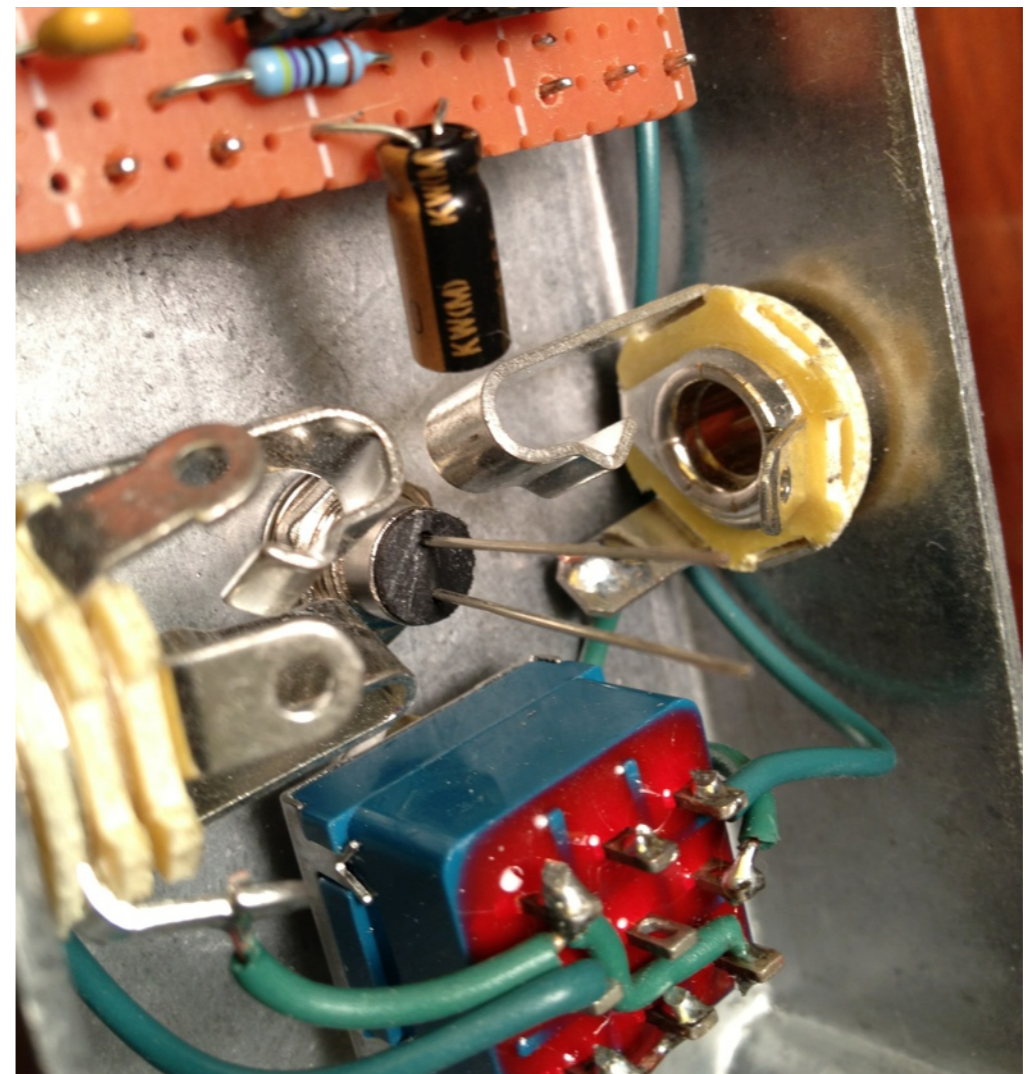

Here you can see the positive (longer) leg of the LED soldered to the switch.

Loop the negative (shorter) LED lead around one end of the 4.7K resistor and solder them together.

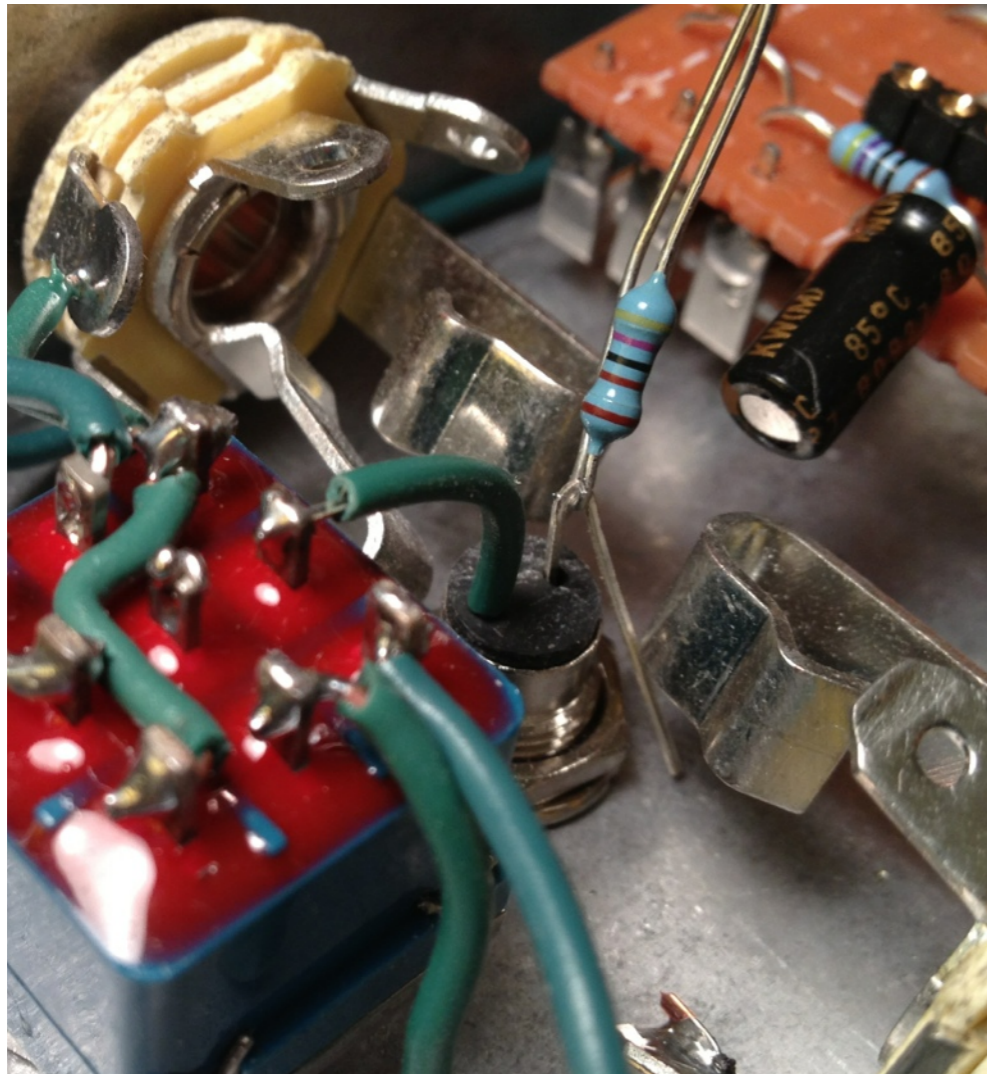

Solder the -9V (black) wire from the PCB and the -9V (black) wire from the 9V battery snap to the other end of the 4.7K resistor.

You can wrap these together and crimp the wire. Solder and snip off the excess.

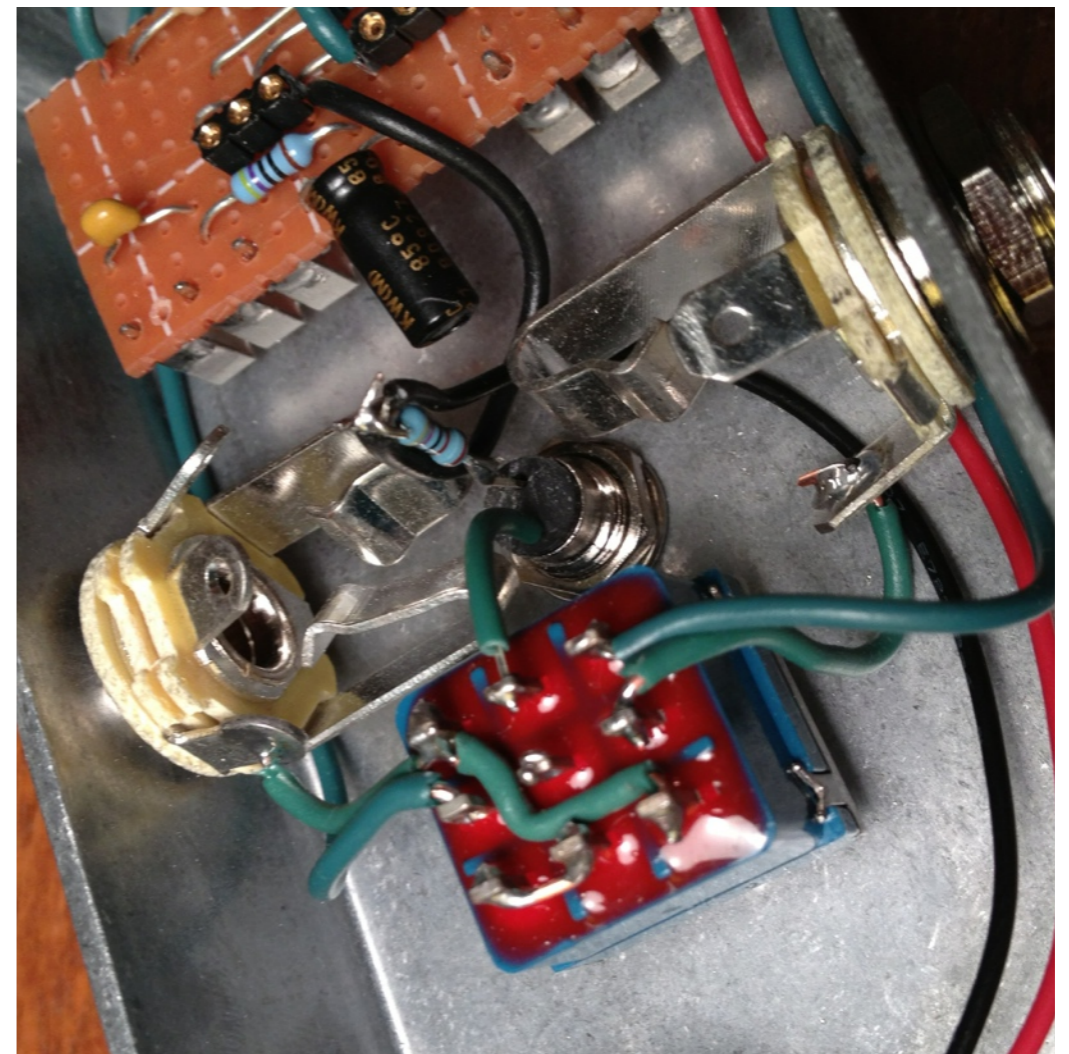

You can apply or bit of heat-shrink tubing to the LED solder junction to prevent it from shorting out against other connection, or just wrap the connections with electrical tape.



Solder a short length of wire to the footswitch's middle-center lug.





Solder the other end of this wire to the input jack's innermost lug **together with** the circuit board's +9v wire (the one connected to the hole at row A/ column A).

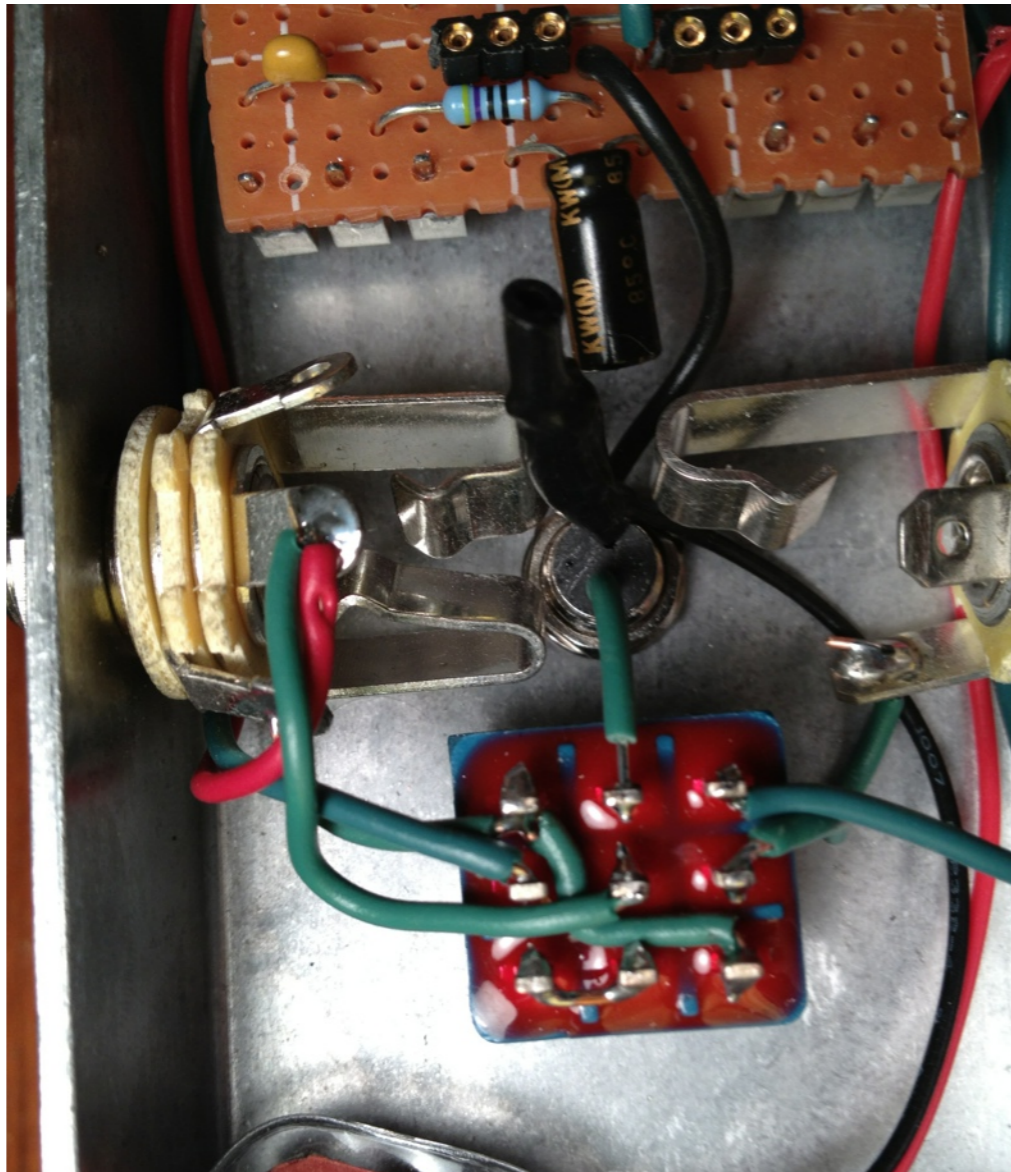

Solder the battery clip's red wire to the input jack's middle lug. (Middle, that is, relative to the side of the enclosure.) This is Stereo ring connection.

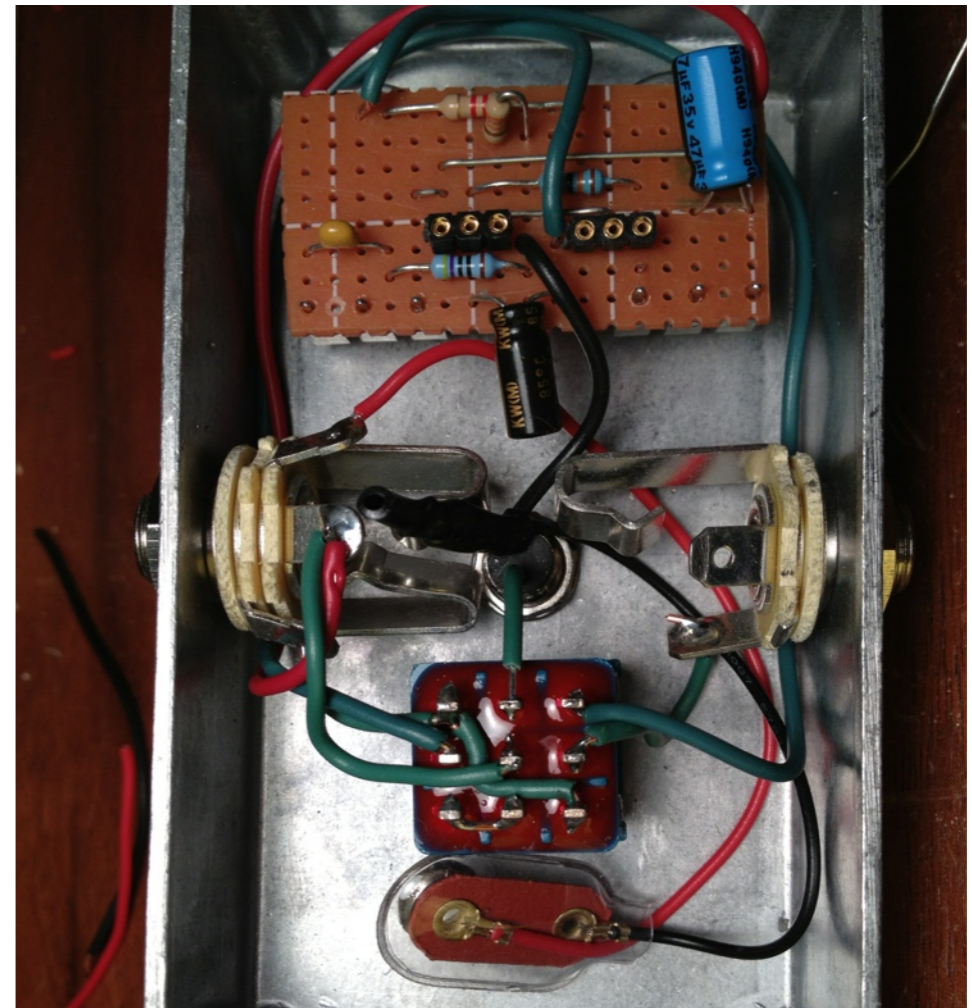

Insert the transistors, trimming their leads as necessary. (Your transistors may look different from these.)

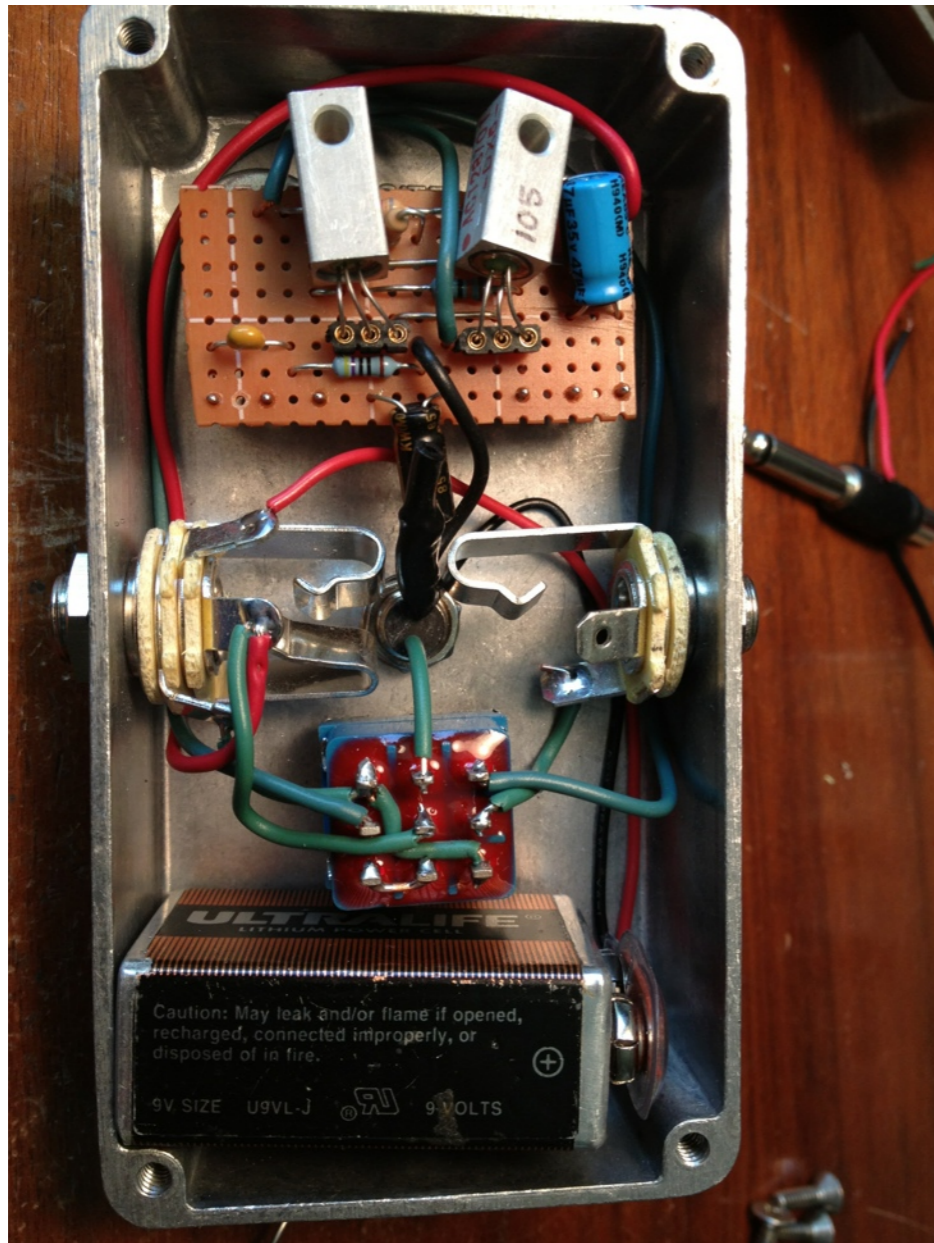

Gently bend the transistors and large capacitors so that they won't touch the back of the enclosure when you screw it in place. (Don't worry about the output jack's empty lug — the jack is grounded via contact with the enclosure.)

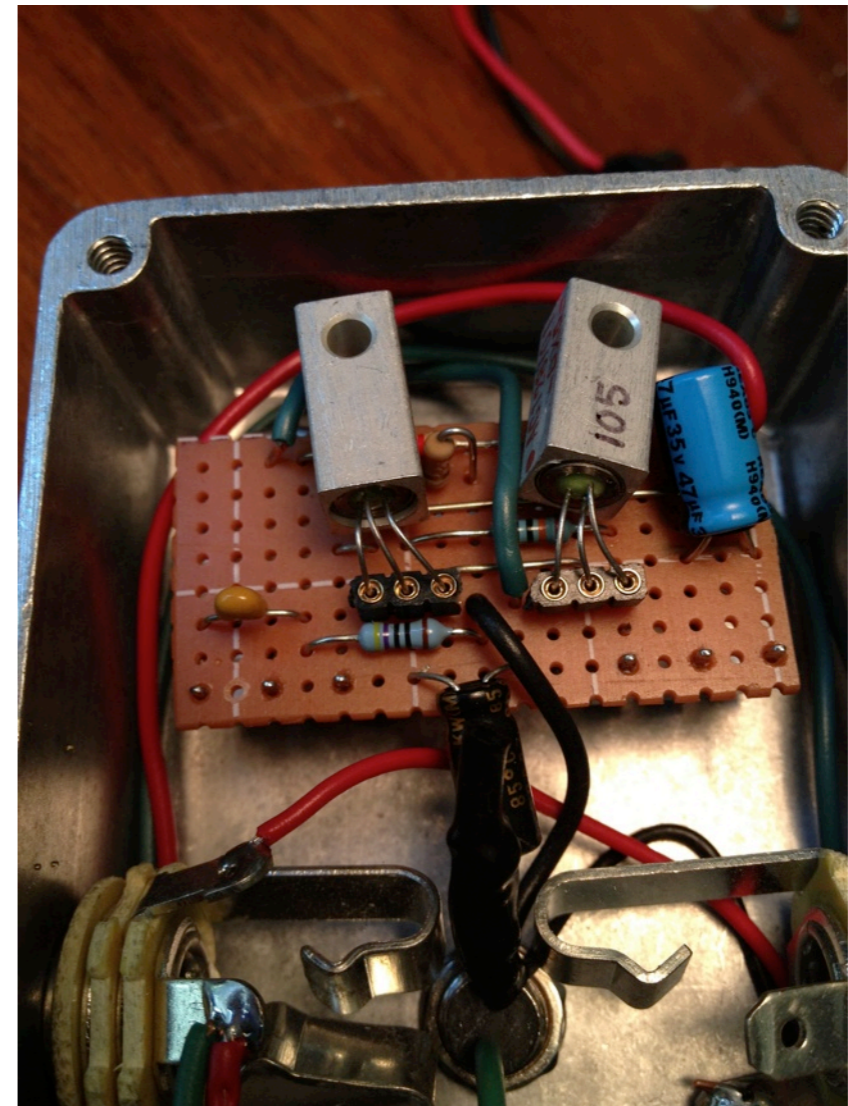

Attach your knobs of choice.

Insert a jack into the input (on the right side, when viewed from this perspective) to verify that the LED is working correctly.



Plug in and play.

For troubleshooting tips, visit [super-freq](#) or [tone-fiend](#), where friendly fuzz freaks gladly dispense free advice. :)